



EVENT DATES: 17-19 Oct 2023

EXHIBITION: 18-19 Oct

CONFERENCE: 17-18 Oct

REGISTRATION: 17-19 Oct

LOCATION: RAI Amsterdam, Europe Complex,
Entrance K; Hall 1/5; Amtrium

2023

EXHIBITOR MANUAL

Arabella Miller
Senior Events Manager
+44 (0) 7739686733

arabella.martin-nunn@aviationweek.co.uk

Ylenia Mezzetti
Events Executive
+44 (0)7827254444

ylenia.mezzetti@aviationweek.co.uk

CONTENTS

Contents

Introduction

- 3** Welcome
- 4** Event Basics
- 5** Show Schedule
- 6** Contacts - Exhibitor Services/Suppliers
- 8** Contacts - Aviation Week MRO

General Information

- 9** Accessibility
- 12** Badges
- 13** Emergencies
- 14** Hotel Accommodation
- 15** Services for All Attendees
- 17** Transportation/Parking

Show Information/Policies

- 18** Alcohol, Drinks, Cocktail Receptions
- 19** Balloons/Lighter than Air Objects
- 20** Demonstrations and Sound
- 21** Meetings in the Exhibition Hall
- 22** Multi-story Exhibits
- 23** Photography/Video

Booth Design/EAC/Contractors/Display Rules

- 24** Booth Design Submission
- 25** Booth Equipment
- 26** Complex Stands
- 28** Display Rules
- 33** Exhibitor Appointed Contractors (EACs)
- 37** Hanging Signs/Rigging
- 38** Health & Safety
- 41** Insurance

Freight and Shipping

- 42** Freight/Shipping
- 45** Traffic
- 46** Material Handling - Empty Containers

Exhibitor Services

- 48** Carpet / Flooring
- 49** Catering/Food & Beverage
- 50** Cleaning / Waste
- 51** Electric
- 52** Forklift Rental
- 53** Furniture
- 54** Internet for Exhibitors
- 56** Marketing Opportunities
- 57** Meeting Room Rental
- 58** Program Book/Online Exhibitor Profile
- 59** Sustainability
- 60** Glossary
- 63** FAQs

EVENT DATES:

17-19 Oct 2023

EXHIBITION

18-19 Oct

CONFERENCE

17-18 Oct

REGISTRATION

17-19 Oct

LOCATION:

RAI Amsterdam
Hall 1/5

Thank you for exhibiting at MRO Europe 2023 at the RAI Amsterdam. We look forward to helping exhibitors, attendees, contractors, stand builders navigate through the show.

The MRO Europe Exhibitor Resource Center is available to help guide you through the process of exhibiting at an MRO show. The ERC can be found [HERE](#).

The primary suppliers/vendors for this event are:

1. Freeman — Freeman is the general services contractor, click here where you can order:

- Shell Scheme Questions
- Graphics
- Flooring
- Furniture

2. RAI Amsterdam — [Click here](#) to access the Webshop where you can order:

Electric	Cleaning
Parking	Internet
Rigging	Catering

3. TWI/CEVA

- Material
- Handling
 - Empty
- Containers
- Forklift Rental

Forms are available in the [MRO Europe Exhibitor Resource Center](#)

Thank you again for exhibiting. We look forward to helping you in any way we can.

MRO Europe
 Europaplein 24, 1078 GZ
 Amsterdam, Netherlands

Conference: Amtrium
Exhibition: Halls 1/5
Entrance: K

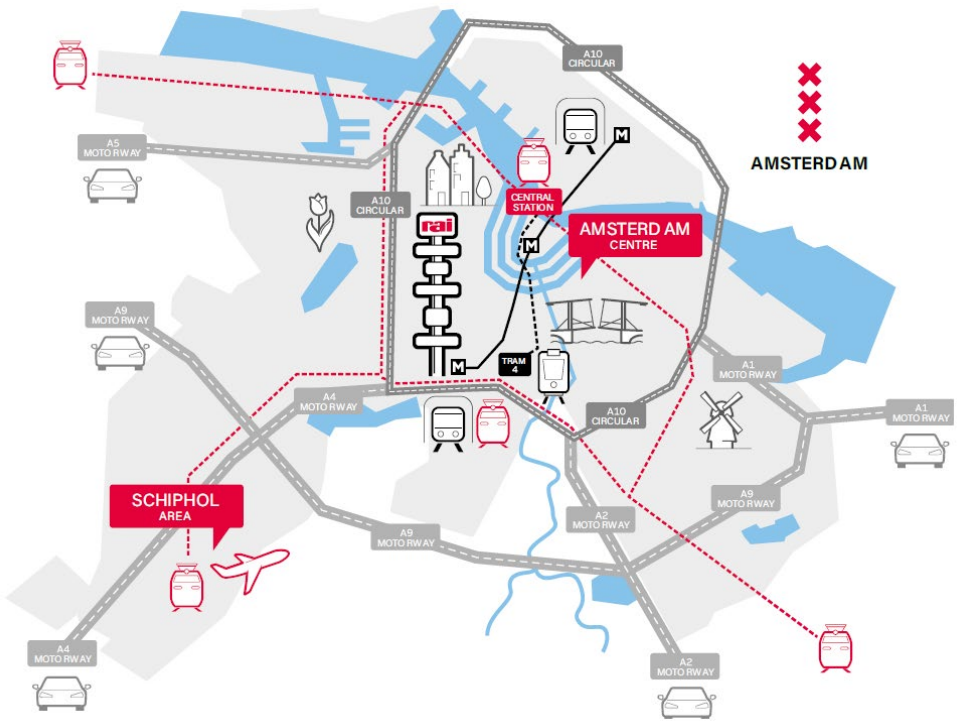

EVENT DATES:

17-19 Oct 2023

EXHIBITION

18-19 Oct

CONFERENCE

17-18 Oct

REGISTRATION

17-19 Oct

LOCATION:

RAI Amsterdam
 Halls 1/5

Below you will find all the dates and times for the event. Please be aware that some of the times may be subject to change. If any changes to this schedule are made we will alert you via email.

Build-up

Exhibitor Move-in:

SUNDAY, 15TH OCTOBER	09:00 – 18:00	Raw Space Only
MONDAY, 16TH OCTOBER	08:00 – 19:00	Raw Space Only
TUESDAY, 17TH OCTOBER	08:00 – 15:00	Raw Space (Construction)
	15:00 – 19:00	Raw Space (Decoration Only)
	08:00 – 19:00	Shell Scheme

The exhibition will be open for visitors

WEDNESDAY, 18TH OCTOBER	9:30 - 17:30
THURSDAY, 19TH OCTOBER	09:30 – 16:00

**Exhibitors can access the hall from 8am on show open days*

Conference Hours

TUESDAY, 17TH OCTOBER	09:30 - 17:45
WEDNESDAY, 18TH OCTOBER	09:30 – 16:00

Registration Hours

(Registration will take place inside the Hall)

TUESDAY 17TH OCTOBER	08:00 – 18:00
WEDNESDAY 18TH OCTOBER	08:00 – 17:30
THURSDAY 19TH OCTOBER	08:00 – 16:00

Breakdown

THURSDAY 19 TH OCTOBER	16:00 - 20:00	(16:00 – 16:00 removal of hand-held goods only)
FRIDAY 20TH OCTOBER	08:00 - 13:00	

Please note for the build-up & breakdown:

- Safety Shoes (Steel Toes) and PPE must be worn during build-up / breakdown (no open-toed shoes). Plus hardhats must be worn when red light is flashing in the hall. Entrance may be refused by security if this is not adhered to.
- Late working is not permitted, stand designs must consider the build-up / breakdown schedule
- Your stand electricity will be turned off 30 minutes after the show closes. Temporary electricians can be ordered from RAI Amsterdam for build-up and breakdown.
- Please keep all gangways clear of stand furnishings, supplies, boxes. The gangways need to be clear in order for the carpet to be pulled up.
- Empty containers will begin to be returned after the gangway carpet has been pulled up. Gangways must be clear to pull up carpet!
- You must leave your stand swept clean and remove all floor tape. Any remaining waste will be removed and billed back to the exhibiting company.

Contacts - Exhibitor Services/Suppliers

Aviation Week’s MRO Europe team has partnered with the list of suppliers below. The MRO Europe Exhibitor Resource Center is available to help guide you through the process of exhibiting at an MRO show. The ERC can be found [HERE](#).

You will find all of the necessary forms and general information to complete your exhibition experience. If you cannot find information in the ERC, please contact:

Arabella Miller
Senior Events Manager
+44 (0) 7739686733
events@aviationweek.co.uk

Supplier	Services	Early Order Deadline
<p>RAI Amsterdam Venue Services Webshop Email: exhibitorservices@rai.nl</p>	<p>Catering Internet Rigging Water & Waste Cleaning Piped Services Electrics Hosts / Hostesses</p>	<p>18th September</p>

Contacts - Exhibitor Services/Suppliers

Freeman

T: +44 (0) 2038935702
 E: EMEA.ExhibitorServices@freemanco.com
 W: <https://mroeurope2023.freemanemeaevents.com/>

Shell Scheme
 Nameboards
 Floor
 Coverings
 Furniture
 Custom Build

18th
 September

Booth Plans/Design Approval

All island and/or raw-space booths must submit their plans online:
<https://app.smartsheet.com/b/form/630bd606ed654c27930263b0e53a9ad5>
 E: mroeurope@abraxys.com

Due 1st September (complex stands)

Due 15th September (non-complex stands)

Exhibitor Appointed Contractors/Insurance

Ylenia Mezzetti
<https://fs2.formsite.com/AW-Events/form58/index.html>

All Exhibitors and EACs will have to complete an online health and safety induction in order to access the hall during setup times.

Due 1st September

Audio Visual

ACS Audio Visual Solutions
 E: SalesRai@acsaudiovisual.com
 T: +31 (0)20 549 1515

18th September

Freight/Shipping Onsite:

CEVA Showfreight
 Attn: Mark Jackson
 T: +44 (0)330 587 7427
 E: Mark.Jackson@cevalogistics.com

Material Handling
 Empty Containers
 Forklift Rental

See Section for deadlines

Freight/Shipping: TWI

Shipping from USA & Canada:
 Tyler Hunt
 T: +1 702 691 9091
 E: thunt@twigroup.com

Freight/Shipping

See Section for Deadlines

Lead Retrieval

[Capture Technologies](http://www.capturetechnologies.com)
sales@ct.events
 +1 973 809 7600

Lead Retrieval

5th September

Contacts - Aviation Week MRO

EVENT DATES:

17-19 Oct 2023

EXHIBITION

18-19 Oct

CONFERENCE

17-18 Oct

REGISTRATION

17-19 Oct

LOCATION:

RAI Amsterdam
Halls 1/5

General & Logistical Information

Arabella Miller
Senior Manager, Events
+44 (0) 7739686733
arabella.martin-nunn@aviationweek.co.uk

Ylenia Mezzetti
Events Executive
+44 (0)7827254444
ylenia.mezzetti@aviationweek.co.uk

Registration

Virginia Gongora
Registration Manager
+1 212 204 4202
events@aviationweek.com

Customer Service

events@aviationweek.co.uk

Sponsorship & Exhibit Opportunities

Beth Eddy & Mimi Smith
(Americas)
+1 561 279 4646 or +1 800 240 7645
betheddy@aviationexhibits.com or
mimismith@aviationexhibits.com

Mike Elmes & Matt Elmes (EMEA/Russia & CIS)
+44-1206-321639
mike.elmes@aerospacemedia.co.uk or

Margaret Chong
(Singapore)
T: +65 9736 1722
Margaret@accessgroup.aero

Clive Richardson
(Asia-Pacific)
Director, Exhibit Sales
+44 (0) 7501 185257
Clive@accessgroup.aero

Press/Media

Elizabeth Kelley Grace
The Buzz Agency
+1 855 525 2899
Elizabeth@thebuzzagency.net
Press releases: Send all press releases and photos to mro@aviationweek.com

Editorial Content

Hannah Bonnett
Conference Producer
+44 7827 284 127
hannah.bonnett@aviationweek.co.uk
[@AvWeekHannah](https://twitter.com/AvWeekHannah)

Tom Broughton
Conference Producer
M: +44 20 8052 0487
Tom.Broughton@informa.com

Marketing Opportunities

Mark Thomas
Senior Marketing Manager
+44 (0) 7979 530 166
mark.thomas@aviationweek.co.uk

Marketing Partnerships

Erving Dockery Tradeshow Manager
+1.818.237.5879
+1.646.479.6997
erving.dockery@aviationweek.com

Management

Lydia Janow, CMP
Managing Director, Events & Tradeshows
+1 646 257 4553
ljanow@aviationweek.com

EVENT DATES:

17-19 Oct 2023

EXHIBITION

18-19 Oct

CONFERENCE

17-18 Oct

REGISTRATION

17-19 Oct

LOCATION:

RAI Amsterdam
Halls 1/5

Mobility Scooters

Mobility scooters are welcome at the RAI.

Wheelchairs

RAI Amsterdam is accessible for people using a wheelchair. The aisles at the show floor It is possible to borrow a wheelchair. A reservation is needed and can be made by sending an email to eventservices@rai.nl and provide us with the following information:

Name

Phone number

Pick up date

Event / trade name

Your reservation is complete after the confirmation e-mail. A deposit and a valid ID is mandatory.

Wheelchair assistants get free access to events organised by RAI Amsterdam. The person using the wheelchair will need to show a valid disability card and will need to pay for his/her own ticket. When borrowing a wheelchair at RAI Amsterdam, the assistant will not receive free entry.

Parking with a disability

People with an official European parking card for the disabled (GPK) can use these special parking spaces, which are located close to the exit of the building. Visitors with an official 'disability card' (GPK) can report to the lodge employees of the P7 parking garage for quick and easy access to a good parking space. This can be reached by following the route P RAI 7, from there we refer to the best parking space. Regular parking fees apply.

RAI Amsterdam is accessible for people using a wheelchair. The aisles at the show floor are spacious and the surface is flat. Elevators and disability toilets are available

Animals

The RAI welcomes all guidance and assistance dogs. No other dogs/pets permitted.

EVENT DATES:
17-19 Oct 2023

EXHIBITION
18-19 Oct

CONFERENCE
17-18 Oct

REGISTRATION
17-19 Oct

LOCATION:
RAI Amsterdam
Halls 1/5

All attendees, exhibitors/sponsors/visitors/speakers/etc. need to be registered as attendees for the event. Exhibitors need to be registered as exhibitors (not visitors) in order to have access to the exhibition hall during setup periods.

Exhibitor Appointed Contractors (EACs)/Stand Builders

Exhibitor Appointed Contractors (EACs) do not need to register as attendees. All EACs will be required to register through the online health and safety induction portal.

The Participants, Hirers or other relevant natural or legal persons are primarily responsible for safety, including the safety of their staff and any third parties used by them.

EACs must complete the EAC form for show management at:

<https://fs2.formsite.com/AW-Events/form58/index.html>

Build-up and breakdown badges

During the build-up and breakdown periods, RAI Amsterdam is only accessible with a valid access badge. This also applies to stand builders and/or suppliers. This policy is implemented in order that we know exactly who is present in the RAI and can act appropriately should an emergency situation arise.

Builders and suppliers can apply for setup badges [online](#)
This is in addition to the EAC registration.

After registering, you will receive a voucher with which you can pick up the build-up and breakdown badge at various locations within the RAI. Registration on site is also possible, but may result in waiting times.

Exhibitor Event Badge

Click [HERE](https://mroeuropa.aviationweek.com) (mroeuropa.aviationweek.com and select Register tab) to register your team. Exhibitors who would like to attend conference sessions may also purchase discounted conference/session badges by choosing either Exhibitor All Access or Exhibitor/Individual Sessions. You will need a promotion code in order to receive your discount, please contact events@aviationweek.co.uk

Booth personnel is unlimited at the MRO events.

Please do not arrange any meetings or invite clients to your booth during set-up hours. They will not be permitted in the exhibit hall with visitor badges.

Registration Hours

Tuesday, 17 October	08:00 – 18:00
Wednesday, 18 October	08:00 – 17:30
Thursday, 19 October	08:00 – 14:00

Registration will take place inside the Hall.

EVENT DATES:

17-19 Oct 2023

EXHIBITION

18-19 Oct

CONFERENCE

17-18 Oct

REGISTRATION

17-19 Oct

LOCATION:

RAI Amsterdam
Halls 1/5

Emergencies such as accidents, fire, theft (persons caught in the act), public unrest and other crisis situations should be immediately reported to telephone number +31 (0)20 549 1234. You should state: who you are; what is the nature of the emergency; where it has happened; whether there are any victims. If you are not in any personal danger, stay with the victims! Wait for expert help, reassure the victims and, where possible, administer first aid or provide other assistance.

RAI Amsterdam has a crisis management plan designed to ensure that the people and resources of the Convention Centre are prepared as well as possible to deal with emergencies. This plan regulates how staff, visitors and others involved must be brought to safety as quickly as possible. A floor plan showing escape routes is displayed at various locations in the Convention Centre.

If a message ordering evacuation of the Convention Centre or certain parts of it is announced over the RAI's public address system, the instructions should be obeyed without delay. Upon hearing the evacuation alarm, everyone should immediately leave the building by the nearest emergency exit and gather at the nearest assembly point. Lifts may not be used for this purpose.

In the case of fire:

- Think of your own safety
- Assess the fire and try to extinguish it if this can be done safely;
- If you cannot extinguish the fire, break the glass of the fire alarm;
- Always report the fire by calling number 020 549 1234, stating the exact location and nature of the fire;
- If possible, lead any people who are in danger to a safe place.

Evacuation:

When the evacuation alarm is sounded everyone should immediately leave the workplace by a safe route and proceed to the nearest safe assembly area outside the building. Assembly areas can be recognised by the assembly area icon.

First Aid:

First aid facilities will be available at all times during the show including during the stand build-up and breakdown periods. First aid services for Events are planned by RAI Safety & Security. This department is also responsible for the possible deployment of in-house emergency response staff in the case of an emergency.

EVENT DATES:

17-19 Oct 2023

EXHIBITION

18-19 Oct

CONFERENCE

17-18 Oct

REGISTRATION

17-19 Oct

LOCATION:

RAI Amsterdam
Halls 1/5

UC The Source is MRO Europe's ONLY official hotel provider endorsed by Aviation Week Network.

All other solicitations are not endorsed or supported by Aviation Week, many are actually SCAM sites; therefore we ask that you do not book rooms with these companies.

When comparing rates, know that most hotel rate quotes here have breakfast included in the rate. If a lower rate is available with the same requirements to anyone at the time of the program, our attendees will get the lower rate regardless of how it is marketed.

How to make a Reservation:

Please select the hotel of your choice. You will be directed to click onto their online website or an alternative option will be provided.

Please note that each hotel has different cancellation policies.

Any request of five (5) or more rooms will be considered a sub-block and will require a separate group contract with penalty in full should they release or cancel block from date of confirmation. Contact UC, The Source directly for group requests: una.cote@ucthesource.com

There is a [list of hotels](#) on the MRO Europe Web site.

EVENT DATES:

17-19 Oct 2023

EXHIBITION

18-19 Oct

CONFERENCE

17-18 Oct

REGISTRATION

17-19 Oct

LOCATION:

RAI Amsterdam
Halls 1/5

ATM/Bureau de Change

An ATM can be found at two of entrances (D and K) of the RAI building. The information desks at various entrances can give you directions to their exact locations.

Business Center

The RAI Business Centre is located in the Passage below the Elicium (accessible via Entrance D, take the escalator down) and offers a wide range of services such as:

- copying, printing, binding
- design
- office supplies

The Business Centre is opened normally at regular exhibition and conference times.

Contact RAI Business Centre

Phone +31 (0) 20 549 16 02

E-mail businesscentre-RAI@canon-bs.nl

Children

Due to the business nature of this event, children under 16 are not permitted into the Exhibition Hall or the Conference during installation, official show days and teardown. Children ages 16 and older will be admitted to the Exhibition Hall during official hours, provided that they are registered, pay appropriate fees and with the understanding that they are the sole responsibility of an accompanying adult.

Cloakrooms

The cloakroom will be open during the show hours and located at Entrance K. There will be a small charge for items left in the cloakroom.

Conference Proceedings

A notification via e-mail from Aviation Week to conference attendees only (if you purchased individual sessions, you do not qualify to receive the conference proceedings) will be sent when these proceedings are available, usually 1-2 weeks after the event.

Event Attire

Business smart attire is appropriate throughout the exhibition, conference and all related events. Be sure to pack a light sweater or jacket for the evening. (No jeans or sneakers during official show events or show hours).

Lost Property

Notice of property that has been lost or found in the Convention Centre can be given on the iLost RAI website <https://ilost.co/en/org/rai-amsterdam>.

Personal Wheeled Vehicles

Hoverboards, skateboards, segways, scooters, rollerblades, and bicycles are not permitted for use within the venue.

EVENT DATES:

17-19 Oct 2023

EXHIBITION

18-19 Oct

CONFERENCE

17-18 Oct

REGISTRATION

17-19 Oct

LOCATION:

RAI Amsterdam
Halls 1/5

Prayer Room

The Prayer Room has a washroom and two private cubicles where people of all faiths can pray or meditate in a peaceful environment. The Prayer Room is always open and accessible via Entrance D at level -1. The two private cubicles for prayer/meditation can be locked from the inside.

Smoking

Smoking is prohibited by law in the RAI buildings. RAI has extended this ban to electronic cigarettes (e-cigarettes), so that their use in the RAI buildings is also prohibited. The ban extends to the underground car parks. Smoking outdoors on the RAI site is permitted in the vicinity of the designated areas, which are indicated by the smoking symbol. Smokers are expected not to smoke near entrances and exits and must deposit cigarette stubs in ashtrays.

Smoking is prohibited inside the Convention Centre, including in the underground car parks. Areas where smoking is prohibited are indicated by No Smoking signs.

Smoking is permitted outdoors at the RAI only in the designated areas marked with a Smoking Area sign (figure 2). Cigarette butts must be discarded in the ashtrays provided in these areas.

Security officers monitor and enforce compliance with these rules on smoking.

WiFi

During this event there will be a free wifi network available. This network is suitable for common social media apps, email and browsing the web. Although this network is free, it is used by thousands of visitors at the same time. If you want a little more certainty than the free network, then there is also RAI Premium wifi available to purchase.

EVENT DATES:

17-19 Oct 2023

EXHIBITION

18-19 Oct

CONFERENCE

17-18 Oct

REGISTRATION

17-19 Oct

LOCATION:

RAI Amsterdam
 Halls 1/5

By Train

Railway station Amsterdam RAI is 300 metres from the RAI and has direct connection with Duivendrecht, Amsterdam Amstel, Amsterdam Zuid and Schiphol railwaystations, which are linked to the international InterCity network. Follow the signs RAI Amsterdam when you leave the station.

By Tram, metro and bus

Tram route 4 between the centre of Amsterdam, Amsterdam Centraal and the RAI (stop at Europaplein). From the Amstel railway station you can reach the RAI via metro 51 or bus route 65. Metro 51 also runs to Amsterdam Central Station.

By Taxi

To guarantee the quality of our taxi service and for logistical reasons, we only allow TCA taxis on the premises to pick up visitors. At many events there will be a special TCA taxi stop on the RAI site. If this is not the case, our reception staff will be happy to help ordering a TCA taxi. If you would like to use another taxi, then the pickup point will be outside the RAI area.

By Car

Directly on approaching Amsterdam via the motorway A1, A2 or A4 and entering the ring road (A10), the RAI is indicated on the sign boards. RAI Amsterdam is located along-side the ring road (exit 9). From the exit the route to the car parks is indicated.

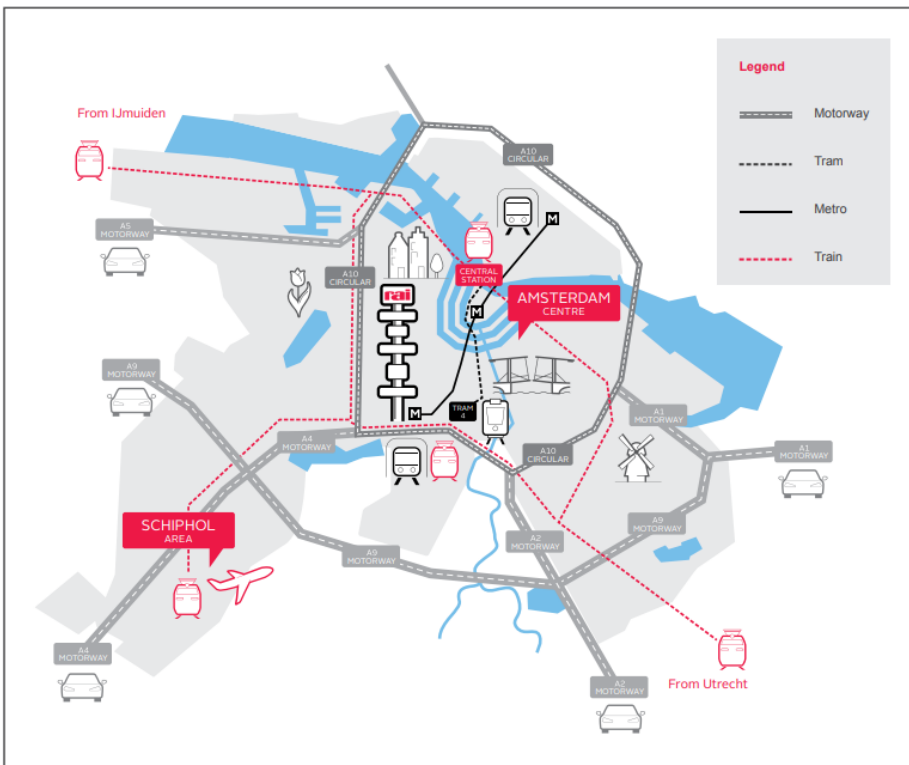

Alcohol, Drinks, Cocktail Receptions

EVENT DATES:

17-19 Oct 2023

EXHIBITION

18-19 Oct

CONFERENCE

17-18 Oct

REGISTRATION

17-19 Oct

LOCATION:

RAI Amsterdam
Halls 1/5

Amsterdam RAI is the exclusive provider of all food and beverage services at MRO Europe.

Show Management requests that all alcoholic beverages be served after 1 pm and must take place in the exhibition hall only. No alcoholic beverages can be removed from the exhibition and all receptions must end by the time the exhibition hall closes for the day. No receptions are permitted after official exhibition hours.

The Show facility requires that ALL food and beverages distributed by exhibitors, attendees or sponsors be purchased solely from the venue itself. There are no exceptions. The Show facility reserves the right to confiscate any items considered a violation of this policy without compensation and may eject the offender from the premises.

Show Management will not be liable for any damages to anyone who violates this policy. Any person or business entity that furnishes liquor to a guest has a civil and legal duty to do so responsibly. Show Management recommends that exhibitor research the liquor laws in the jurisdiction where the Show will be held to evaluate its exposure and meet any requirements for liability insurance. If exhibitor intends on serving any liquor from its booth.

PLEASE NOTE: Only the official caterer may serve any alcoholic beverages. Show Management also requests that to minimize any liability alcoholic beverages be served during a limited time period.

Please order with Amsterdam RAI online: [RAI Webshop](#)

Show Information/Policies Balloons/Lighter than Air Objects

EVENT DATES:

17-19 Oct 2023

EXHIBITION

18-19 Oct

CONFERENCE

17-18 Oct

REGISTRATION

17-19 Oct

LOCATION:

RAI Amsterdam
Halls 1/5

Show Management has a Balloon Policy in place that prohibits the use of helium filled balloons, either for displays, exhibits or general public access.

Drones, flying objects, etc. are strictly prohibited.

DEMONSTRATIONS

Exhibitor shall observe the “good neighbor” policy at all times and not intrude upon or disrupt other exhibitors while they are conducting business on the Show floor. Exhibits should be conducted in a manner not objectionable or offensive to neighboring booths. All demonstrations and the use of photographers, musicians, entertainers, loud speakers, sound system equipment and noise-making devices must be restricted to within the exhibitor’s booth. Entertaining attendees in booths must be arranged so that exhibitor’s personnel and attendees do not block aisles or overlap into neighboring exhibits. Operation of any equipment for demonstration purposes must be pre-approved in writing by Show Management. Show Management reserves the right to determine when any demonstrations become objectionable or interfere with adjacent exhibit spaces and may, if necessary, require that they be discontinued.

SOUND

Disruption or noise level from any demonstration or sound system must be kept to a minimum and may not interfere with others. The use of devices for mechanical reproduction of sound or music is permitted (up to 85 decibels) but must be controlled and not be projected outside the confines of the exhibit booth. No noise makers or anything not in keeping with the character and high standards of the Show may be distributed or used by exhibitor in the exhibit area. Show Management reserves the right to determine at what point a disruption or sound level constitutes interference with other exhibits and must be discontinued.

Any exhibitor planning music, bands, entertainment, etc. must receive written permission from Show Management. Show Management reserves the right to determine when any demonstrations become objectionable or interfere with adjacent exhibit spaces and may, if necessary, require that they be discontinued.

For questions and approvals, please contact Arabella.martin-nunn@aviationweek.co.uk

Show Information/Policies

Meetings in the Exhibition Hall

EVENT DATES:

17-19 Oct 2023

EXHIBITION

18-19 Oct

CONFERENCE

17-18 Oct

REGISTRATION

17-19 Oct

LOCATION:

RAI Amsterdam
Halls 1/5

Show Management requests that customer meetings not take place during show hours outside of the Exhibition Hall.

Meeting rooms may be available on premises. Please contact your sales rep for more information. See contact page for information.

Please refrain from setting meetings and inviting customers to your booth during set-up hours.
Only Exhibitors and Contractors are permitted in the exhibition hall.
Speakers, visitors, conference attendees will not be permitted in the hall.

EVENT DATES:

17-19 Oct 2023

EXHIBITION

18-19 Oct

CONFERENCE

17-18 Oct

REGISTRATION

17-19 Oct

LOCATION:

RAI Amsterdam
Halls 1/5

Multi-story exhibits include any display fixture that includes two or more levels.

Multi-story Exhibits requires prior approval by the exhibit facility, and/or relevant local government agency and show management and will have additional fees applied.

Multi-story exhibits are permitted in island booths only, and the maximum height, including hanging signs is 6 meters. Double-decker (multi-story) booths require additional structural approvals, fire watch, fire marshal approvals, etc.

Fees

There are additional fees associated with Multi-story exhibits. For MRO Europe, the fee is US\$45 per sqm assessed by show management. This fee along with a signed addendum to your exhibitor booth contract must be received before your booth can be approved.

There is also a charge for the permit from the RAI. The RAI permit can be obtained from the RAI [webshop](#).

For more information about adding a second story and the approval process, please contact Arabella.martin-nunn@aviationweek.co.uk

All Island and/or raw-space booths must submit their plans online [here](#) no later than Friday 1st September if they are complex and no later than Friday 15th September if they are non-complex.

EVENT DATES:

17-19 Oct 2023

EXHIBITION

18-19 Oct

CONFERENCE

17-18 Oct

REGISTRATION

17-19 Oct

LOCATION:

RAI Amsterdam
Halls 1/5

PHOTOS AND VIDEOS. Exhibitor may take photos or videos of its displays; however, exhibitor is not permitted to directly take pictures of any other display or instruct others to take such pictures without written permission of Show Management and the exhibitor whose display is being photographed. Notwithstanding the foregoing, exhibitor authorizes Show Management and its Representatives (as defined in Section 16 below) to photograph and/or record all or any part of the Show (including, without limitation, exhibitor's exhibit space and personnel), and exhibitor hereby grants Show Management the worldwide, perpetual, royalty free right and license to reproduce, distribute, transmit, publicly perform and publicly display all such photographs and recordings (and any derivative works thereof) in any medium (now existing or hereafter developed).

EVENT DATES:

17-19 Oct 2023

EXHIBITION

18-19 Oct

CONFERENCE

17-18 Oct

REGISTRATION

17-19 Oct

LOCATION:

RAI Amsterdam
Halls 1/5

Submitting plans for approval

All raw space booths must submit their designs and documentation using this link:
<https://app.smartsheet.com/b/form/630bd606ed654c27930263b0e53a9ad5>

1. Detailed, scaled structural drawings showing:
 - Plan and section views of the stand
 - Elevations including any steelwork and staircase details
 - Full details of any hanging structure or signage, including material used, weight and method of attachment to the truss
 - Width and position of gangways within the stand
 - Floor and/or roof loading
 - Specifications of materials used
2. Structural calculations
3. Risk assessment (to include fire hazards working at height & fire hazards including naked flame, LPG)
4. Method statement (to include planned date of arrival on site to commence build up and contact details of your project manager on site responsible for build up and breakdown).
5. Public liability Insurance document
6. Written confirmation from an independent structural engineer, with adequate Professional indemnity cover, that the design is safe for its purpose. For this purpose, we will send your complete sets of information to an appointed structural engineer working on the event.

Note: All storage rooms, meeting rooms, enclosed spaces with doors inside your booth must include a vision panel

All Island and/or raw-space booths must submit their plans online [here](#) no later than Friday 1st September if they are complex and no later than Friday 15th September if they are non-complex.

Shell Scheme Stands

- Each shell scheme stand will be 2.48m high with white Infill panels
 - White vinyl lettering to a 300mm high Royal Blue fascia infills to each open elevation.
 - Each shell scheme stand will include 1 x 500w Socket & 2 x 100w Spotlights.
- Your shell scheme stand carpet will be grey and the gangways will be blue.

Please note that the exhibitor needs to:

- Provide graphics if desired
- Order furniture
- Register staff as exhibitors

Accessories for your shell scheme booth can be ordered from Freeman. **A link to order shell scheme extras is available here.**

Early ordering Deadline: 18th September 2023

Additional services including Internet, catering, etc can be ordered via forms and links in the [Exhibitor Resource Center](#).

Raw Space Stands

Raw space booths include only the space on the show floor. The exhibitor is responsible for the design, construction and furnishing of the stand.

You will be expected to produce a professionally built custom stand with a high level of finish and safety compliance and one that is in line with the high-quality, professional nature of the event. Please note space only stands do not receive carpet, walls or electrics.

All Island and/or raw-space booths must submit their plans online [here](#) no later than Friday 1st September if they are complex and no later than Friday 15th September if they are non-complex.

Additional services including Internet, catering, floral, etc can be ordered via forms and links in the [Exhibitor Resource Center](#).

Early ordering Deadline: 18th September 2023

EVENT DATES:

17-19 Oct 2023

EXHIBITION

18-19 Oct

CONFERENCE

17-18 Oct

REGISTRATION

17--19 Oct

LOCATION:

RAI Amsterdam
Halls 1/5

Complex Structures

All raw space exhibitors (regardless of size) must submit plans for approval to show management. Please send all schematics with elevations/materials used, a risk assessment and method statement to [online](#) no later than Friday 1st September.

What is a Complex Structure?

A complex structure is defined as any form of construction which would normally be designed by an engineer and has, through a risk assessment, been found to provide a significant risk.

Complete Display Rules & Guidelines can be found in the MRO Europe Exhibitor Resource Center. Please make sure your stand is in compliance with all of the display and health and safety guidelines. The maximum allowable height for island booths is 4 meters (13 feet). A variance to 6 meters (20 feet) may be issued with permission from show management. The maximum height for linear (inline) stands is 2.5 meters (8 feet).

All stands that are over 4m in height, and/or deemed complex for any reason will need to be approved by a structural engineer appointed by Show Management. The exhibitor will be billed directly by the structural engineer.

Complex structures:

- Any structure over 4m in height
- Any stage or platform over 600mm in height and all platforms and stages for public use
- Stairs
- Temporary tiered seating
- Suspended items e.g. lighting rigs
- Sound/light towers

Guidelines for Submission

1. **Designs must include all elevations including those of hanging signs. Plans submitted without elevations, will not be accepted.**
2. Submission of information should be in the form of drawings and calculations, not photographs or rough sketches, as it is not possible to assess the structure without details of the stand.
3. Drawings should contain enough detail to show exactly how the stand will be constructed including baseplates, joint construction support details etc.
4. Calculations are to prove that the stand is stable and capable of supporting the loads of anything which will be supported i.e.: lights, speakers plasma screens etc. A nominal load should be applied for wind (0.15 kN/m²) although this appears not to apply in the halls stands have been affected by doors being open. A calculation should also be carried out for overturning this assumed to be the impact of a person (0.75 kN) at a height of 1.5m above the ground.
5. No fixing is allowed into the hall floor at these venues, other means of securing the stands need to be considered.

Hanging/Suspended Structures and Signs

All suspended elements which are constructed from timber and/or metal structure will be deemed as complex structures. Suspended elements consists of canopy, fascia, trusses clad with timber etc. Fabric banners, formax signs, screens, lighting trusses, AV equipment, lighting bars will not require structural sign off.

Booth Design/EAC/Contractors/Display Rules

Complex Stands

EVENT DATES:

17-19 Oct 2023

EXHIBITION

18-19 Oct

CONFERENCE

17-18 Oct

REGISTRATION

17--19 Oct

LOCATION:

RAI Amsterdam
Halls 1/5

Drawings should contain enough detail to show exactly how the stand will be rigged including connection details between venues rigging point to suspended elements, constructed details of joints between elements etc.

All lifting equipment/lifting tackle (i.e. eye bolts, threaded rod, steel cables, and hooks) should comply with all current, relevant legislation and must be rated. Test certificate should be made available for inspection.

All Island and/or raw-space booths must submit their plans online [here](#) no later than Friday 1st September if they are complex and no later than Friday 15th September if they are non-complex.

MRO Europe

Shell scheme refers to a pre-built structure that is provided by the show organizer. It is part of a package of benefits.

Contents and furnishing of the shell scheme booth can not exceed the height of the shell scheme structure and custom builds are NOT permitted. Carpet is provided by the organizer.

SHELL SCHEME GENERAL GUIDELINES

- ALL internal stand fitting and displays are contained within the shell scheme structure and do not exceed 2.5 meters in height.
- No display materials or logos may be fixed to the shell scheme fascia panel. No fixings may be made to the walls by piercing or screwing anything onto the panels or beams.
- Exhibitors may affix lightweight photographs and technical information sheets etc. direct to the shell scheme walls with good quality double-sided adhesive pads or similar, provided such material can be removed without damage to the wall panels, any damage made to the panels will result in a charge.
- Exhibitors that purchase stands as shell scheme are not permitted to remove the shell scheme and build their own structures. Raw spaces booths are a minimum of 18sqm.

Fascia

The fascia is the name board sits at the top of your stand and will carry your Company Name and Stand Number

MODIFICATIONS TO SHELL SCHEME BOOTHS

- Modifications to shell scheme is at the discretion of the organizers
- Shell scheme wall panels absolutely cannot be removed
- Custom wall panels cannot be built in front of the shell scheme panels or adhered to the shell scheme structure
- Platforms are not permitted (unless required by venue - determined on show to show basis)

Removing Fascia and Gridwork

- The fascia and/or gridwork can only be removed from your booth with permission from show management.
- Show management will determine if removal is possible based on location and structural integrity of the adjoining booths
- All companies removing fascia and/or gridwork MUST submit plans for approval from show management
- No shell scheme booth can exceed the 2.5 meter height limit regardless of whether or not fascia and gridwork have been removed. This includes signage, furnishings, lights, etc.

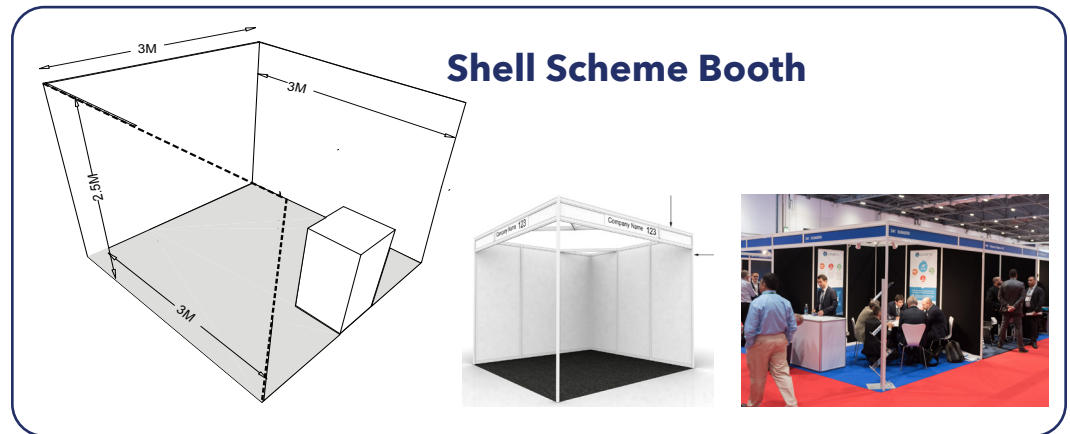

SHELL SCHEME BOOTH (Min 9sqm)

- Arranged in a straight line
- Has neighbors on either side (in-line)
- One side exposed to aisle (in-line)
- Two sides exposed to aisle, (corner)
- Maximum height for graphics and furnishings is 2.5m
- Hanging signs are not permitted
- Shell scheme framework cannot be removed

RAW SPACE

Island Booths

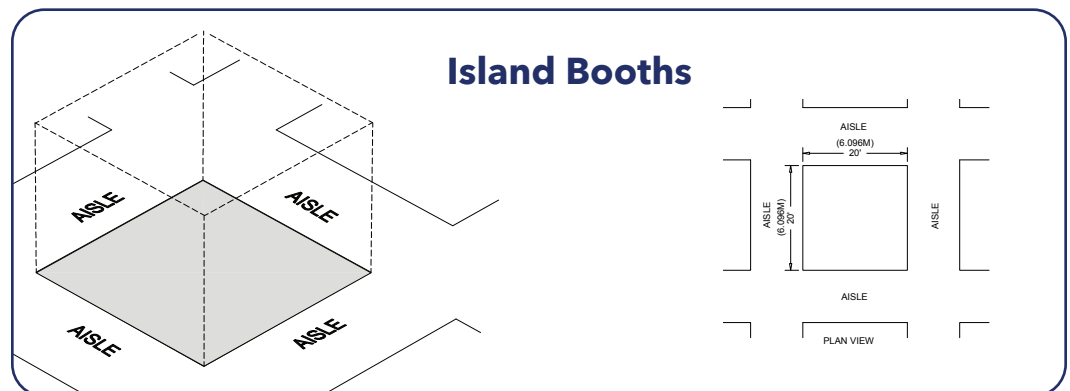

- Any size booth exposed to aisles on all four sides
- Hanging Signs permitted. Rigging must be completed by official contractor.
- The entire cubic content of the space may be used up to the maximum allowable height, which is 4 meters, or 6 meters with Show Management's approval including signage.
- All raw space booth plans must be approved by show management. Please send all schematics with elevations/ materials used to <https://app.smartsheet.com/b/form/ab9743a2252f4238b4624ce852518705>.
- Additional approvals and guidelines may be required by the venue.
- For 18sqm island booths, Hanging signs must be flat (double-sided).

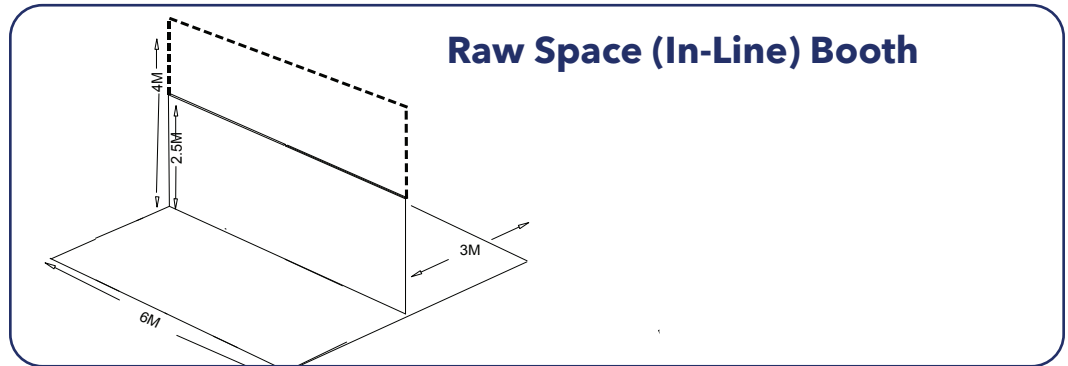

RAW SPACE BOOTH (Min 18sqm)

- Arranged in a straight line, or back-to-back with a neighbor (a 36 sqm island split into two 18sqm booths)
- Three sides exposed to aisle (corner)
- Maximum back wall height is 2.5 meters, can go up to 4 m with show management permission
- Design must include a solid wall separating booth from adjacent booth. Wall must measure complete length of the booth and be 2.5m high (can go up to 4m with show management permission)
- Entire surface of back wall must be cleanly “finished” and painted or covered.
- Hanging signs are not permitted
- All raw space booth plans must be approved by show management.
- Displaying your booth number on the stand will make you easier to find for attendees

~~ALL RAW SPACE BOOTHS MUST SUBMIT PLANS FOR APPROVAL. Upload to: <https://app.smartsheet.com/b/form/630bd606ed654c27930263b0e53a9ad5>~~

Submitting plans for approval

1. Submission of information should be in the form of drawings and calculations, not photographs or rough sketches, as it is not possible to assess the structure without details of the stand.
2. **Plans that do not include all elevations will not be accepted, including all hanging signs.**
3. Drawings should contain enough detail to show exactly how the stand will be constructed including baseplates, joint construction support details etc.
4. No fixing is allowed into the hall floor at these venues, other means of securing the stands need to be considered.
6. **Failure to submit your designs may result in an inability to exhibit.**

Hanging Signs

- Hanging signs are permitted in island booths only.
- Maximum allowed height is 4 meters (16 feet), 6 meters with permission from show management. Distance is measured from floor to the top of the sign.
- Hanging Signs and Graphics should be set back 3 meters (10 feet) from adjacent booths and be directly over contracted space only.

Towers (free-standing exhibit component separate from the main exhibit fixture)

- height restriction is the same as applies to the exhibit space configuration

Multi-story Exhibits

- Display fixture includes two or more levels
- Multi-story Exhibit requires prior approval by the exhibit facility, and/or relevant local government agency and show management and will have additional fees applied by show management and/or local health and safety organization
- For more information about adding a second story and the approval process, please contact Arabella Miller, arabella.martin-nunn@aviationweek.co.uk, +44 77 396 86 733.

General Decorating Guidelines

- **Any portion of a display that extends above or beyond that of the booth adjoining to the rear or side must be finished with paint or drape at the Exhibitor's expense.** Any portion of an Exhibitor's booth facing an aisle must be finished.
- Drip pans and scrap buckets should be provided for operating machinery to prevent lubricants, paints, etc., from staining the floor causing a slippage hazard.
- Painting may be done inside the exhibit hall as long as drop cloths are used to prevent any damage to the building. No spray painting is permitted inside the exhibit halls.
- Paint must be removed nightly and all cans must be tightly closed to prevent their contents from staining the floor, causing a slippage hazard, and tracking of paint, etc., over another Exhibitor's carpet.
- Exhibitors are liable for any damage they cause (or third party authorized by them) to the walls, floors, columns, doors, windows, etc., during the installation, operating and dismantling of their exhibits.

Lighting

- Exhibitors must adhere to the following suggested minimum guidelines when determining booth lighting:
 - o No lighting, fixtures, lighting trusses, or overhead lighting are allowed outside the boundaries of the exhibit space. Exhibitors intending to use hanging light systems must submit drawings to exhibition management for approval.
 - o Lighting, including gobos, must be directed to the inner confines of the booth space. Lighting should not project onto other exhibits or exhibition aisles.
 - o Lighting which is potentially harmful, such as lasers or ultraviolet lighting, must comply with facility rules and be approved in writing by exhibition management.
 - o Lighting that spins, rotates, pulsates, and other specialized lighting effects must be in good taste and not interfere with neighboring Exhibitors or otherwise detract from the general atmosphere of the event.
 - o Currently some convention facilities are not allowing quartz halogen lighting fixtures in exhibits due to potential fire hazards. Check with exhibition management.
 - o Reduced lighting for theater areas must be approved by the exhibition organizer, the utility provider, and the exhibit facility.

Carpeting

- The use of carpeting or other professional floor covering is required by each Exhibitor. These floor coverings must not be sealed to the floors in such a manner as to injure the floor or be so installed as to be a hazard to public safety or as to endanger the public. Exhibitors are responsible for the final condition of the floor in their space. The edges of raised flooring may be inclined, providing the slope is gradual and gentle.
- If an exhibitor sets his booth without floor covering, carpet will be ordered at the exhibitor's expense.
- If exhibitor will be setting up late and is bringing their own carpet, they must notify show management or carpet will be ordered at exhibitor's expense.

Structural Integrity

All exhibit displays should be designed and erected in a manner that will withstand normal contact or vibration caused by neighboring exhibitors, hall laborers, or installation/dismantling equipment, such as fork lifts. Displays should also be able to withstand moderate wind effects that may occur in the exhibit hall when freight doors are open. Refer to local building codes that regulate temporary structures.

Flammable and Toxic Materials

All materials used in display construction or decorating should be made of fire retardant materials and be certified as flame retardant. Samples should also be available for testing. Materials that cannot be treated to meet the requirements should not be used. A flame-proofing certificate should be available for inspection. Exhibitors should be aware of local regulations regarding fire/safety and environment which must be adhered to.

Exhibitors should dispose of any waste products they generate during the exhibition in accordance with guidelines established by the Environmental Protection Agency and the facility.

Storage

Fire regulations in most exhibit facilities prohibit storing product, literature, empty packing containers, or packing materials behind back drapes or under draped tables. In most cases, however, exhibitors may store a limited supply of literature or product appropriately within the booth area, so long as these items do not impede access to utility services, create a safety problem, or look unsightly.

Local Jurisdiction

All MRO exhibitors must also comply with any local/venue regulations that are not outlined in this document.

General Setup Information

- Stands should be designed so that they can be built in the time allocated for setup. Please refer to the Exhibitor Resource Center or Show Manual for exact setup times.
- All aisles/gangways must be cleared by the announced time for aisle carpet to be installed.

Booth Design/EAC/Contractors/Display Rules Exhibitor Appointed Contractors (EACs)

Exhibitor Appointed Contractors (EACs)/Stand Builders

An Exhibitor Appointed Contractor (EAC) is any company other than Aviation Week's official service contractors. Exhibitors are responsible for informing all appointed contractors of the rules, requirements and regulations and for ensuring their compliance. Any and all outside vendors must fulfill the following requirements.

Any exhibitor must insure that non-official vendors hired to perform any of the following services at Aviation Week's event must comply with the rules, requirements and regulations.

- Audio Visual
- Carpet Rental / Flooring
- Computer Rentals
- Exhibit Rental/Booth Rental
- Exhibitor Marketing
- Floral
- Furniture
- Installation & Dismantling / Display Labor / Supervision
- Personnel / Temporary Help / Models
- Photography / Video / Film
- Security / Guard Service
- Transportation / Freight Carrier

Note: for electrical, plumbing, internet, telephone, cleaning, material handling, rigging - the exhibitor and/or EAC must utilize the official vendor designated by Aviation Week.

If an exhibitor plans to use a firm other than the "Official Show Vendor", please fill out the Aviation Week Exhibitor Appointed Contractor form (EAC). The form can be found here: <https://fs2.formsite.com/AW-Events/form58/index.html>

This form must be completed and returned to Aviation Week no later than four (4) weeks prior to the event.

Important Notes:

- EACs should supply a list of all full-time employees who will be installing, dismantling or working in the exhibiting company's booth. Aviation Week management also requires that exhibitor appointed contractors furnish a list of all subcontractors they will use during installation, show days and dismantling. Any company that is not an approved exhibitor appointed contractor or does not appear on an appointed exhibitor contractor's list of approved subcontractors will be denied access to the show floor. Exhibitor appointed contractors must collect the proper COIs from their subcontractor(s), and maintain the original certificates (photocopies and faxes are not acceptable) on file for review by Aviation Week management.
- During the build-up and breakdown periods, the exhibition is only accessible with a valid access badge. This also applies to stand builders and/or suppliers. This policy is implemented in order that we know exactly who is present in the hall and can act appropriately should an emergency situation arise.

Booth Design/EAC/Contractors/Display Rules Exhibitor Appointed Contractors (EACs)

Exhibitor Appointed Contractors (EACs)/Stand Builders

An Exhibitor Appointed Contractor (EAC) is any company other than Aviation Week's official service contractors. Exhibitors are responsible for informing all appointed contractors of the rules, requirements and regulations and for ensuring their compliance. Any and all outside vendors must fulfill the following requirements.

Any exhibitor must insure that non-official vendors hired to perform any of the following services at Aviation Week's event must comply with the rules, requirements and regulations.

- Audio Visual
- Carpet Rental / Flooring
- Computer Rentals
- Exhibit Rental/Booth Rental
- Exhibitor Marketing
- Floral
- Furniture
- Installation & Dismantling / Display Labor / Supervision
- Personnel / Temporary Help / Models
- Photography / Video / Film
- Security / Guard Service
- Transportation / Freight Carrier

Note: for electrical, plumbing, internet, telephone, cleaning, drayage, rigging – the exhibitor and/or EAC must utilize the official vendor designated by Aviation Week.

If an exhibitor plans to use a firm other than the "Official Show Vendor", please fill out the Aviation Week Exhibitor Appointed Contractor form (EAC). The form can be found here: <https://fs2.formsite.com/AW-Events/form58/index.html>

This form must be completed and returned to Aviation Week no later than four (4) weeks prior to the event.

Important Notes:

- EACs should supply a list of all full-time employees who will be installing, dismantling or working in the exhibiting company's booth. Aviation Week management also requires that exhibitor appointed contractors furnish a list of all subcontractors they will use during installation, show days and dismantling. Any company that is not an approved exhibitor appointed contractor or does not appear on an appointed exhibitor contractor's list of approved subcontractors will be denied access to the show floor. Exhibitor appointed contractors must collect the proper COIs from their subcontractor(s), and maintain the original certificates (photocopies and faxes are not acceptable) on file for review by Aviation Week management.
- During the build-up and breakdown periods, RAI Amsterdam is only accessible with a valid access badge. This also applies to stand builders and/or suppliers. This policy is implemented in order that we know exactly who is present in the RAI and can act appropriately should an emergency situation arise.

Booth Design/EAC/Contractors/Display Rules Exhibitor Appointed Contractors (EACs)

EVENT DATES:

17-19 Oct 2023

EXHIBITION

18-19 Oct

CONFERENCE

17-18 Oct

REGISTRATION

17-18 Oct

LOCATION:

RAI Amsterdam
Halls 1/5

- All EACs and all subcontractors must display company ID with photo all times while on property.
- All EACs agree to abide by the rules and regulations set forth by Aviation Week in the exhibitor terms and conditions and the Exhibitor Resource Center. EACs may operate only out of the confines of their client's booth. Separate service desks and/ or work areas, storage areas or other work facilities will not be permitted at Aviation Week's event. The show aisles and public space are not part of the Exhibitor's booth space.
- All EACs must comply with local labor agreements and practices and may not commit any acts that could lead to work stoppages, strikes or labor problems.
- All EACs must adhere to the move-in, move-out schedule. Exhibitors will be responsible for any additional expense incurred by Aviation Week should deadlines not be met.
- Exhibitors are liable for restoring their exhibit area to its original condition (i.e. free of any tape, debris and other remnants of use)
- All personnel under the employment of the EACs must obtain wrist bands. Bands will not be issued until insurance requirements are met.
- It is the responsibility of the exhibiting company to ensure that each EAC adheres to all official rules and regulations of the Event as set forth by Aviation Week.
- All EACs will not solicit business on the Show Floor.
- Use of electric scooters is prohibited
- While aisle carpeting is being installed, containers, jockey boxes, ladders and any other equipment must be removed completely from the show floor
- EAC may photograph client booth(s) only.
- EAC is prohibited from using the MRO Show name, logo or any likeness for the purpose of promoting or marketing its own activities.
- The EAC is responsible for the actions and activities of any of its sub-contractors.
- EAC will not establish service desks anywhere inside the exhibit hall. The EAC will utilize space as designated by Show Management, outside the exhibit hall
- The EAC is responsible for adherence to the Exhibitor Rules & Regulations and the Display Regulations & Height Restrictions.
- Provide adequate notice to Show Management of the exhibitors who have retained them and the services to be performed for each exhibitor.
- Have a true and valid order for service from an exhibitor in advance of the Show setup date and in their possession on-site.
- All safety guidelines are to be observed.
- EAC must be dressed in suitable attire at all times.

EVENT DATES:

17-19 Oct 2023

EXHIBITION

18-19 Oct

CONFERENCE

17-18 Oct

REGISTRATION

17-18 Oct

LOCATION:

RAI Amsterdam
Halls 1/5

Amsterdam RAI is the exclusive provider of rigging services for MRO Europe 2023

All Island and/or raw-space booths must submit their plans online [here](#) no later than Friday 1st September if they are complex and no later than Friday 15th September if they are non-complex.

- All rigging must be ordered by 18 September. Orders received after this date will be subject to a 20% surcharge.
- Hanging Signs and Graphics are allowed in Island booths only. All rigging is to be hung at 6m from the show floor to the bottom of the rigged item.
- All orders for rigging must follow the required guidelines and be submitted with a clear precise rigging plan at the time of ordering.
- Any changes required due to incorrect rigging plans will be subject to a surcharge.
- All rigging plans must show the location of each rigging point in relation to the stand using metric measurements.
- All rigging must be within the perimeter of the stand
- The stand orientation must be detailed by showing the location of the main entrance and by the stands on other neighboring three sides.

Glossary/Guidelines

DROPWIRES — Drop wires should only be used to suspend light weight static loads, e.g. banners/ simple light weight structures.

6mm steel wire rope c/w bullet end connection. Any length. Static load only up to a max of 50kg. Not to be used as a lifting point i.e. chain hoists may not be suspended from drop wires. Ordering of a drop wire does not include hoisting and fixing service this must be ordered separately (see below)

LIFTING POINTS – All lifting points are assembled using accessories capable of supporting a load of 5KN. Allow- able loading per point needs to be checked prior to tenancy as point loading is location dependant within the venue. Ordering of a lifting point does not include the supply of a chain hoist. This must be ordered separately (see below). There is a charge for connecting clients own chain hoists to the venue. Lifting points that require spreader beams will be charged as two lifting points. The spreader truss beams used to facilitate the lifting points is not charged for.

BANNER RIGGING — For all PVC/FABRIC BANNERS. PVC banners should be produced with a 75mm pocket at the top and bottom. Up to 2500mm wide (inc 2 wires and tube) is one price. ("B01") and 2551mm –6000mm wide is another ("B02") Banners wider than 6m, box banners or unusual shapes / material will be priced upon application. Banners must be delivered by the deadline. This date is set before the first day of tenancy to allow us to rig the banner/s before anyone arrives. If banners do not get delivered before this date then a hoist and fix charge will apply (see below). Banners will be rigged to your plan. Make sure you have included all the correct information as any on site banner moves / banner shuffles will be charged.

TRUSS — Our most commonly used truss is Thomas 305 super truss. This is charged out at per meter. We do have other sizes of truss in stock, prices upon application.

CATENARY WIRES — Our catenary wires are made from 10mm steel wire. Make sure that your snap hooks fit this dimension. Catenary wires are charged at a per meter rate, and are calculated to the next termination beam.

ELECTRIC CHAIN HOIST INCLUDING CONTROL EQUIPMENT. — Our hoists will not usually be installed before the first day of tenancy. Electrical chain hoist load redundancy can be taken into consideration on an individual hoist basis. If the point load on the hoist is less than 50% of the WLL of the hoist including an allowance for dynamic load, then a secondary suspension will not be required.

EVENT DATES:

17-19 Oct 2023

EXHIBITION

17-19 Oct 2023

CONFERENCE

17-18 Oct

REGISTRATION

17-18 Oct

LOCATION:

RAI Amsterdam
Halls 1/5

HEADLINE SITE RULES

1. The way you work and the equipment and materials you use must be safe
2. Suitable PPE must be worn at all times. Appropriate footwear must be worn as a minimum.
4. Smoking, alcohol and drugs are prohibited from site.
5. A permit must be given by the Site Manager before any "hot" works.
6. All accidents and incidents must be reported to the event organiser.
7. Good housekeeping is required at all times.

PERSONAL PROTECTIVE EQUIPMENT (PPE)

Hard Hats

Head protection may consist of an industrial helmet. Workers are obliged to wear a safety helmet when there is a danger of falling objects. A helmet must comply with EN397 and bear a CE marking. A padded cap is not a helmet, does not protect against falling objects, and is therefore not allowed.

High Visibility Clothing

Hi-visibility yellow or orange coloured vests to BS EN 471 standard should be worn on the show floor, service yard, load in areas and other associated areas when vehicles or plant are operating in the area.

Safety Footwear / Other PPE

Safety shoes (steel toes) must be worn during the setup and breakdown periods in the exhibition halls, meeting rooms and lounges. During these periods, other passers-by in the Convention Centre are strongly advised not to enter the exhibition halls, meeting rooms and lounges (unless they are wearing safety shoes).

Safety Harness

Safety Harness must be worn when operating a Cherry Picker

STAND CONSTRUCTION

- It should be possible to reach and leave stands (places of work) safely.
- A fire extinguisher must be kept within reach when carrying out work that poses a fire risk.
- Combustible items or parts of a stand must be shielded from the work.
- The task of connecting stands to the Convention Centre power supply is entrusted to a recognised electrical contractor used by RAI Amsterdam. Power may not be generated in any other way.

FALL PROTECTION

People working at a height of above 2.5 metres or at heights where there is a risk of falling are obliged to wear fall protection equipment: a body harness, hook and lifeline with fall protection mechanism.

EVENT DATES:

17-19 Oct 2023

EXHIBITION

17-19 Oct 2023

CONFERENCE

17-18 Oct

REGISTRATION

17-18 Oct

LOCATION:

RAI Amsterdam
Halls 1/5

VEHICLE MOVEMENTS

Contractors and exhibitors must adhere to the restrictions and directions put in place and provided by the venue to ensure that vehicles and pedestrians are segregated.

Vehicle drivers must:

- Adhere to venue and/or general contractor guidelines
- Not exceed venue/general contractor speed limits
- Wear a driver restraint (seat belt) while operating
- Announce (use horn) when moving from the loading area to event floor
- Not carry passengers unless they are seated in a passenger seat
- Not load or unload in areas where it will block fire exits or routes
- Not leave engines running inside the halls unless it is to operate the equipment
- Secure vehicles at all times and remove the keys when unattended
- Not operate any mobile vehicle whilst using a cellular device

ELECTRICAL SAFETY AND EQUIPMENT

The nominated contractor will liaise with the venue directly to ensure that the installation is verified as safe prior to it being energized. The contractor must provide the necessary transformers for supplying this equipment. Extension leads required for the work must be used on the reduced voltage side of the supply. All electrical equipment must be suitable for use with the local venue supply. Exhibitors and contractors that provide their own extension leads and adaptors and are responsible for them being properly wired and electrically tested. All electrical equipment and extension cords used must be in sound condition, with all live conductors properly protected. Extension cords may not be connected together known as daisy chaining. Electrical equipment must have been subject to combined inspection and test by a qualified electrician, including insulation and earth bonding tests. Inspected equipment must be clearly labelled with inspection labels.

HOT WORKS & NAKED FLAMES

Hot works such as welding, the use of grinders, soldering etc, are prohibited unless advanced notice is given to the Aviation Week's MRO Asia-Pacific Event Organizer and Venue. Permission must be granted, and a specific hot work permit issued prior to commencement of work. Floor management will monitor hot works to ensure that they do not pose a fire safety risk. In general, the following must be in place:

- Immediate area must be clear of other workers, public and vehicles.
- Immediate area must be clear of combustible items
- The operative and others in the immediate area must be suitably protected from risk of burns and damage to eyes
- A suitable fire extinguisher must be provided in close proximity to work area
- A second operative is required to monitor the operation, to keep other people clear and watch for signs of fire and use the fire extinguisher, if necessary

EVENT DATES:

17-19 Oct 2023

EXHIBITION

17-19 Oct 2023

CONFERENCE

17-18 Oct

REGISTRATION

17-18 Oct

LOCATION:

RAI Amsterdam
Halls 1/5

MANUAL HANDLING

Manual Handling is the movement of loads by lifting and carrying by hand. Ideally, mechanical means should be used such as lift trucks, pallet trucks and trollies to reduce the need for manual handling. There must be adequate lighting and clear aisles to allow loads to be carried without the risk of tripping and falling. Operatives moving loads should consider wearing safety boots. Those working with heavy loads may need boots with toe protection to protect the feet from dropped loads.

Factors that should be considered when manual handling are:

- Weight of load
- Size and shape of load
- Posture during manual handling
- The distance the load has to be lifted
- Frequency of manual handling
- Working environment
- Capability of person

INCIDENT REPORTING

All incidents must be reported to the Aviation Week's MRO Europe Event Organiser, in order that treatment can be given and, if necessary, emergency services can be called and directed to the correct location

WORKING AT HEIGHTS

All reasonable steps should be taken to eliminate or minimize work at height. Working at height should be properly planned and supervised with the correct equipment selected for the given job task. Contractors are to ensure that:

- No work is done at height if it is safe and practical to avoid it
- All work at height takes account of conditions that could endanger safety such as high winds or slippery ground
- Access is controlled to prevent other persons working or walking beneath work at heights
- The risk from falling objects are properly controlled. Work platforms must have a toe board to prevent items from falling
- Persons working at height on a mobile elevated work platform should wear head protection as required by the venue
- Plans are in place for emergencies and rescue from height
- Those working at height must be protected by a guard rail or equipped with fall arrest harness (except when using a ladder)
- Personnel involved in work at height are trained and competent
- Ladders can be used when it is not practicable to use a working platform, or the activity is a low risk. Ladders must be in accordance with manufacturer's instructions at all times. The following guidelines must be followed:
 - Ladders must have an "industrial" rating
 - Leaning ladders must be placed at the correct angle
 - Ladders should only be used on level ground and must be secure
 - The top treads or steps must not be used as a platform for work
 - Users should face the ladder at all times whilst climbing or dismounting
 - Only one person should climb or work from a ladder
 - Users should not overreach

EVENT DATES:

17-19 Oct 2023

EXHIBITION

18-19 Oct

CONFERENCE

17-18 Oct

REGISTRATION

17-18 Oct

LOCATION:

RAI Amsterdam
Halls 1/5

Exhibitor is required to carry property and liability insurance in amounts sufficient to cover any losses or liabilities exhibitor may incur in connection with the Show, including without limitation, due to damage or loss to exhibitor's property or injury to the person and/or property of others. Notwithstanding the foregoing and except as otherwise provided in the Exhibitor Resource Center, at all times that exhibitor has access to the Show grounds, exhibitor shall maintain at a minimum the following insurance from an insurance company rated B+ or above by A.M. Best Company (or equivalent insurance rating agency):

General commercial liability insurance, including contractual liability and advertising injury coverage, with a minimum liability limit of not less than \$1,000,000 combined single limit per occurrence and \$2,000,000 aggregate.

Exhibitor's policy should add Informa Media, Inc. and Informa Business Media, Inc. and their respective affiliates, the applicable Show facility, and/or any other official exhibitor service contractor as additional insureds.

By executing the Agreement, exhibitor represents and warrants that it has all such insurance in effect and that it shall maintain all such insurance at least through exhibitor's occupancy of the exhibit space and the Show facility. If requested by Show Management, exhibitor shall provide a certificate of insurance evidencing the required cover- age.

The Certificate of Insurance can be submitted via the EAC form, or sent directly to ylenia.mezzetti@aviationweek.co.uk <https://fs2.formsite.com/AW-Events/form58/index.html>

EVENT DATES:
17-19 Oct 2023

EXHIBITION
18-19 Oct

CONFERENCE
17-18 Oct

REGISTRATION
17-18 Oct

LOCATION:
RAI Amsterdam
Halls 1/5

Without careful planning, shipping everything from brochures to booths can be a difficult and costly process.

Here are some tips and tricks to help guide you through. But, the most important takeaway here is **START PLANNING EARLY**. Take advantage of early bird discounts and alleviate stress by reaching out early to find the best solution for you!

As the official service contractor, TWI is the exclusive provider of freight services. This includes:

- Material handling includes unloading your exhibit material
- Storing in advance at the warehouse
- Delivering to the booth
- Handling empty containers to and from storage
- Removing material from the booth for outbound carriers

Freight must not arrive at Amsterdam RAI prior to first Tenancy date

Please download the [TWI information packet](#) to make shipping/freight arrangements.

ALL consignments must be sent on a freight prepaid basis:

Labels

Each crate should be appropriately labeled on each side. Do not label the top of your container as items may be stacked.

Link for printing your labels: [Shipping Labels](#)

Commercial Invoice/Packing List

Please prepare the invoice/packing list with the following details:

- Commercial invoices and packing lists can be combined on one document if they list quantity, description, value of each item, weight and dimensions of each package.
- Your company's Identification Number and any applicable licensenumbers.
- Complete, precise, simple and non-technical description of all items listed on the invoice
- Electronic copy of each commercial invoice in Excel format should be sent to TWI Operations: Ryan Eagen – Reagen@twigroup.com and our on-site partner CEVA Logistics – Michael Jansen mark.jackson@cevalogistics.com

PACKING

Due to multiple handling of freight cases TWI urges exhibitors to use strong wooden cases. Bolted returnable types of cases that offer protection from the elements are ideal. If your cases are secured with a lock or combination please provide the key or combination for Customs purposes.

EVENT DATES:

17-19 Oct 2023

EXHIBITION

18-19 Oct

CONFERENCE

17-18 Oct

REGISTRATION

17-18 Oct

LOCATION:

RAI Amsterdam
 Halls 1/5

Freight Deadlines

Air Freight – Amsterdam Schiphol	6 October 2023	CONSIGNEE (AIRFREIGHT) CEVA Showfreight MRO Europe 2023 Folkstoneweg 182 1118 LN Schiphol Netherlands Telephone: +44 (0) 33 0587 7427 Contact: Michael Jansen Email: mark.jackson@cevalogistics.com
Sea Freight – Rotterdam	2 October 2023 (Less than container load) 6 October 2023 (Full container load)	CEVA Showfreight MRO Europe 2023 Exhibition Hall/Stand Number Elektronweg 24 3452 AC Utrecht, Netherlands Notify: CEVA Showfreight Attn: Mark Jackson Telephone: +44 (0) 330 587 7427 Email: Mark.jackson@cevalogistics.com
Roadfreight Warehouse Receiving	15 – 17 October 2023	CEVA Showfreight MRO Europe 2023 Exhibition Hall/Stand Number RAI Centre, Europaplein Amsterdam NL 1078 GZ Netherlands <i>NCTS Code: Upon Request</i>

EVENT DATES:

17-19 Oct 2023

EXHIBITION

18-19 Oct

CONFERENCE

17-18 Oct

REGISTRATION

17-18 Oct

LOCATION:

RAI Amsterdam
Halls 1/5

PRE-ADVISE

Please email advance copies of the Airway Bill / Express Release Bill of Lading, commercial invoice, and pre-alert to Tim Marchant with DSV:

Mark Jackson - Mark.jackson@cevalogistics.com

Include TWI Operations in copy:

Ryan Eagen - reagen@twigroup.com

Using a consolidator may delay customs clearance and delivery. Any deconsolidation charges will be passed on to you at cost plus 10%.

SHIPPING FROM THE US & CANADA

Chris Drum

T: +1 702 691 9000

E: cdrum@twigroup.com

INSURANCE

It is recommended that exhibitors provide insurance coverage for their goods from point of departure through to final destination. It is further recommended that such insurance coverage be provided for the transit period and while on-site at the exhibition (including move-in and dismantling periods).

EVENT DATES:

17-19 Oct 2023

EXHIBITION

18-19 Oct

CONFERENCE

17-18 Oct

REGISTRATION

17-18 Oct

LOCATION:

RAI Amsterdam
Halls 1/5

[Click here](#) to view general information on traffic control at the RAI. Approximately 3 weeks prior to the show, the Logistics Management System will be open where you will be able to book a time slot for unloading / loading.

Check back here in October for further details.

Material Handling - Empty Containers

EVENT DATES:

17-19 Oct 2023

EXHIBITION

18-19 Oct

CONFERENCE

17-18 Oct

REGISTRATION

17-18 Oct

LOCATION:

RAI Amsterdam
Halls 1/5

Aviation Week's MRO Europe has partnered with TWI and CEVA Showfreight as our show freight partners.

Material handling includes unloading your exhibit material, storing up to 30 days in advance at the warehouse address, delivering to the booth, the handling of empty containers to and from storage, and removing of material from the booth for reloading onto outbound carriers. It should not be confused with the cost to transport your exhibit material to and from the convention or event.

- Pick up "Empty Labels" at the Service Center. Place a label on each container. Labeled containers will be picked up periodically and stored in non-accessible storage during the show.
- At the close of the show, the empty containers will be returned to the booth in random order. Depending on the size of the show, this process may take several hours.
- In order to get your containers returned to you most expeditiously, please keep all aisles clear after the show concludes. Empty containers are not returned to booths until the carpet has been removed. The quicker the carpet is pulled, the quicker you will get your containers.

STORAGE: Fire regulations in most exhibit facilities prohibit storing product, literature, empty packing containers or packing materials behind back drapes or under draped tables. In most cases, however, Exhibitors may store a limited supply of literature or product appropriately within the booth area, as long as these items do not impede access to utility services, create a safety problem or look unsightly.

To arrange for storage of your empty containers, please contact:

TimMarchant - timothy.marchant@dsv.com

CEVA Showfreight

Mark Jackson

E: Mark.Jackson@cevalogistics.com

EVENT DATES:

17-19 Oct 2023

EXHIBITION

18-19 Oct

CONFERENCE

17-18 Oct

REGISTRATION

17-18 Oct

LOCATION:

RAI Amsterdam
Halls 1/5

Please check the Exhibitor Resource Center for information regarding AV rentals.

EVENT DATES:

17-19 Oct 2023

EXHIBITION

18-19 Oct

CONFERENCE

17-18 Oct

REGISTRATION

17-18 Oct

LOCATION:

RAI Amsterdam
Halls 1/5

All booths must have carpet or management approved flooring. Rental Carpet is available through Freeman.

To meet equal access regulations any raised platform between 4cm - 10cm must have integrated app access. The ramp access must not protrude into the gangway.

The maximum raised floor can be no higher than 10cm.

The aisles will be carpeted in Blue.

You may bring your own flooring; however, you must contact Freeman Exhibitor Services Tel: +44 (0) 20 3893 5702 Email: EMEA.ExhibitorServices@freemanco.com to confirm.

Raised Floors

The use of raised platforms is recommended for stands with water and gas pipes, and/or a lot of electrical wiring across the floor (the stand builder can provide advice on this). When using platforms in a stand, it is important to keep in mind that the sides need to be sealed off neatly finished, and the raised floor must fit within the boundary lines of the stand.

EVENT DATES:

17-19 Oct 2023

EXHIBITION

18-19 Oct

CONFERENCE

17-18 Oct

REGISTRATION

17-18 Oct

LOCATION:

RAI Amsterdam
Halls 1/5

Amsterdam RAI is the exclusive provider of all food and beverage services at MRO Europe.

Show Management requests that all alcoholic beverages be served after 1 pm and must take place in the exhibition hall only. No alcoholic beverages can be removed from the exhibition and all receptions must end by the time the exhibition hall closes for the day. No receptions are permitted after official exhibition hours.

The Show facility requires that ALL food and beverages distributed by exhibitors, attendees or sponsors be purchased solely from the venue itself. There are no exceptions. The Show facility reserves the right to confiscate any items considered a violation of this policy without compensation and may eject the offender from the premises.

Show Management will not be liable for any damages to anyone who violates this policy. Any person or business entity that furnishes liquor to a guest has a civil and legal duty to do so responsibly. Show Management recommends that exhibitor research the liquor laws in the jurisdiction where the Show will be held to evaluate its exposure and meet any requirements for liability insurance. If exhibitor intends on serving any liquor from its booth.

PLEASE NOTE: Only the official caterer may serve any alcoholic beverages. Show Management also requests that to minimize any liability alcoholic beverages be served during a limited time period.

Please [click here](#) to view the options on the Amsterdam RAI webshop

EVENT DATES:

17-19 Oct 2023

EXHIBITION

18-19 Oct

CONFERENCE

17-18 Oct

REGISTRATION

17-19 Oct

LOCATION:

RAI Amsterdam
Halls 1/5

Aviation Week provides an initial stand cleaning for all SHELL SCHEME stands, only. This cleaning takes place prior to the show opening.

Raw space stands DO NOT receive an initial cleaning from show management. Ordering information is available in the [RAI webshop](#).

Stand cleaning includes:

All horizontal surfaces completely clean, every day. The rate is per square metre for the whole event. Please fill out the number of square metres of your stand.

This includes:

- vacuuming
- if necessary mopping the floor (excluding stains caused by shoes)
- cleaning horizontal surfaces of furniture
- emptying waste bins
- clean booth statement

We kindly request you tidy up your stand before you leave, so our team can clean your stand thoroughly.

Waste Disposal :

Waste materials should never be left on-site. Exhibitors are responsible for ensuring everything is removed at the end of the show. This includes any waste left by your appointed contractor and all stand fitting materials, such as graphics, flooring, carpet/carpet tape, packaging materials and excess literature, both during the stand build-up and breakdown periods.

Waste removal is not free of charge and services should be pre-ordered in advance from Amsterdam RAI.

General waste bins and skips are not provided within the halls. It is strongly recommended that you read the information on cleaning and waste within the venue regulations to ensure you have booked the required services - waste removal is significantly cheaper when ordered in advance.

Products, installations and stand materials that are not removed within the published time limits, or are disposed of in an unauthorised way at the venue, will incur a waste disposal fee charged directly to the exhibitor to cover the cost of the appropriate disposal.

Removal of any debris or trash exhibits left in the hall will be billed back to the exhibitor.

EVENT DATES:

17-19 Oct 2023

EXHIBITION

18-19 Oct

CONFERENCE

17-18 Oct

REGISTRATION

17-18 Oct

LOCATION:

RAI Amsterdam
Halls 1/5

Amsterdam RAI are the exclusive provider for Electrics

Early ordering Deadline: 18th September 2023

Shell scheme exhibitors receive 1 x 500w socket and 2 x spotlights.

Raw Space will be required to order power directly through the RAI via the webshop. Some consideration are stated below.

Standard or professional?

Standard power is equal to the power that you use at home. Electricians and standbuilders frequently use 400 Volt - 3 phase power. We named this type of power "professional power". No clue? Then you're fine with standard power.

Some appliances use more power than others. Watercookers, coffee machines and vacuum cleaners use a lot of energy. At home, this issue of concurrent usage of appliances is solved by the use of separate fuses. Here at the RAI, we install multiple outlets that each have a maximum of 3 kiloWatt of power (see below for more info). You can use your own extension cables if you have more appliances than outlets.

Day power or night power?

Day power is required for virtually all of your appliances. For your and our safety, we shut down the main power connection when the RAI closes at night. For some appliances, power during night time is important, e.g. Freezers and some computer servers. For those appliances, you can order a special night power connection that stays on at night. Night power is also known as Continuous power.

Do you need building power?

Your power connection is available from the last buildup day. This way, you can test and use your appliances during the preparation of your event. If you need access to power earlier, e.g. for rigging activities, you can order Building Power. You then have access to power during the entire buildup and breakdown periods. It is possible to order a 20 kW connection specifically for rigging activities.

How much power do appliances use?

Low power appliances < 100 W each

- phone
- laptop
- light
- monitor

Medium power appliances < 1.000 W each

- tv
- extractor fan
- pc
- fridge or freezer

"power-hungry" appliances > 1.000 W each

- Electric kettle
- coffee machine
- vacuum cleaner
- frying pan

Created for indication purposes only. Always check your own appliances.

EVENT DATES:

17-19 Oct 2023

EXHIBITION

18-19 Oct

CONFERENCE

17-18 Oct

REGISTRATION

17-19 Oct

LOCATION:

RAI Amsterdam
Halls 1/5

Forklift orders to install your booth after materials are delivered may be ordered in advance or at show site. We recommend that you order in advance to avoid additional charges at show site.

CEVA Showfreight

Mark Jackson – mark.jackson@cebalogistics.com

EVENT DATES:

17-19 Oct 2023

EXHIBITION

18-19 Oct

CONFERENCE

17-18 Oct

REGISTRATION

17-19 Oct

LOCATION:

RAI Amsterdam
Halls 1/5

Freeman sets the stage for success with temporary furnishings that make lasting impressions. With high-quality furniture in shapes and styles that suit your budget and design needs, Freeman always provides an ideal solution for your exhibit.

- Sleek and professional furniture products transform your exhibit into a destination
- Extensive selection of seating, surfaces, and display fixtures provides a completely custom and comprehensive approach to your brand experience
- No assembly required: Hassle-free shipment, setup, and tear down allow your exhibitors to focus on what matters: new business
- Prices are all-inclusive and cover delivery, installation and material handling with no hidden fees

Order online: <https://mroeuropa2023.freemanemeaevents.com/>

Early ordering Deadline: 18th September 2023

Internet for Exhibitors

Amsterdam RAI is the Exclusive provider of internet services for MRO Europe.

EVENT DATES:

17-19 Oct 2023

EXHIBITION

18-19 Oct

CONFERENCE

17-18 Oct

REGISTRATION

17-19 Oct

LOCATION:

Amsterdam RAI
Halls 1/5

Wired internet

The most stable and reliable connection! If you need an internet connection on your stand for your presentation, streaming video, software demonstration or other critical systems and activities we recommend using a wired internet connection.

Wireless Internet

Multiple wireless options are available. Because of the large amounts of users it's really hard to maintain a stable wifi network. Because of this, we don't really promote the creation of your own wifi network. But if you really need your own wifi network this is allowed if you follow our WiFi regulations.

- The 5 Ghz band is not permitted
- Wifi equipment must be configured on the 2.4 Ghz frequency band with a Transmit Power less than 25mW
- The broadcasted SSID must clearly include the name of the company on the booth and be visible at all times. A hidden SSID is not permitted
- The word 'RAI' or 'rai' is not allowed to be used in any part of an SSID

More information

Internet can be ordered via the RAI webshop.

EVENT DATES:

17-19 Oct 2023

EXHIBITION

18-19 Oct

CONFERENCE

17-18 Oct

REGISTRATION

17-19 Oct

LOCATION:

Amsterdam RAI
Halls 1/5

Exhibitor Lead Retrieval Can Help You!

Say goodbye to the old days of collecting business cards and manually typing them into a CRM! Using rental badge scanning devices or a software installed on your own mobile device, Lead Retrieval eliminates this process, provides a user-friendly scanning method & delivers your leads in your own exhibitor portal, exportable to a CRM friendly format directly after the event. So now your team can start follow-up or marketing tasks much quicker post-event, which as we know is incredibly important.

The scanning process is as simple as tapping “scan” on the device and pointing the device’s camera at the QR code on the badge. The scanner automatically scans the barcode, which significantly speeds up the capture process. The aim is to make the scanning as unobtrusive as possible, so you can focus on what matters – the interaction.

Benefits

- Use your own device or rent one: Rental devices help save battery life, and can be shared amongst team members. Or simply download the app to your own device and start scanning.
- Fast Capture of contact information: Capturing a lead is as simple as pointing the camera at the badge.
- Expedited Lead Delivery/Sales Agility: Receive your own personalized URL and download your leads in a spreadsheet format within 48 hours of show-close, so your sales team can promptly start follow-ups.
- Qualify Leads: Optionally, use custom questions to qualify your leads and show who needs immediate follow-up, or information on a specific product.
- Add Notes: Attach freeform notes at any time to a lead to further assist your sales team.
- Real-time syncing to avoid loss of data: Syncing your captured leads to the cloud ensures no loss of data if device is lost/damaged.
- Improved Customer Interactions: The collection of contact information is so quick/ easy, you can now focus on the customer interaction!

We understand how much time and effort goes into exhibiting your brand, which is why generating quality sales leads is so important. Lead Retrieval software allows you to seamlessly capture all the most recent contact information to update your CRM. Don’t miss out on opportunities, start capturing leads!

Order online [here](#)

P: +1 973.890.7600

E: sales@ct.events

EVENT DATES:

17-19 Oct 2023

EXHIBITION

18-19 Oct

CONFERENCE

17-18 Oct

REGISTRATION

17-19 Oct

LOCATION:

Amsterdam RAI
Halls 1/5

[Click here](#) to view the Engagement Opportunities available!

Official Event Banners

Whether you're sponsoring or exhibiting, now you can use these banners or the ones within your feathr dashboard to post on your websites, blogs and on your email signature footer!

Don't forget to link it to your customized feathr landing page or to the MRO Europe homepage – <https://mroeuropa.aviationweek.com/en/home.html>

Need a customized banner? Contact don.giordano@aviationweek.com with your booth number, logo, specs/size and tag line and we will create one for you.

In addition, we will gladly work with your marketing department to accommodate any special requests. Contact mark.thomas@aviationweek.co.uk

EVENT DATES:

17-19 Oct 2023

Meeting room space may be available for rental in or near the exhibition hall. Please contact your sales rep (please see contacts page) for information.

EXHIBITION

18-19 Oct

Meeting rooms are reserved for exhibitors and sponsors only. Your meeting room includes a boardroom setup, including electricity, tables and chairs. Additional AV/catering/etc. can be ordered from the official contractors.

CONFERENCE

17-18 Oct

Meeting rooms are only available for use during posted exhibition hours. **Exhibitors may not invite customers to meetings before or after show hours.**

REGISTRATION

17-19 Oct

Exhibition Hours

WEDNESDAY 18TH OCTOBER	09:30 - 17:30
THURSDAY 19TH OCTOBER	09:30 – 16:00

LOCATION:

Amsterdam RAI
 Halls 1/5

Program Book/Online Exhibitor Profile

EVENT DATES:

17-19 Oct 2023

EXHIBITION

18-19 Oct

CONFERENCE

17-18 Oct

REGISTRATION

17-19 Oct

LOCATION:

Halls 1/5

As an exhibitor, your company profile is published on the MRO Europe web site, in the official program book. Exhibitors can enter profile information and select industry categories. All changes need to be made by 1 September 2023, or they will not appear in the printed materials. The marketing or primary contact on your account will receive login information to enter or change the profile and select categories.

If you are a returning exhibitor, your profile from last year already appears on the site. Please log into your account when you receive the notification and confirm whether you would like to repeat this listing or make changes.

If you are having trouble logging into your account to make changes please contact events@aviationweek.co.uk

Program Book Advertising

Expand your company's presence during the event. Used as a reference throughout the show by all conference delegates, trade show visitors, and exhibitors, the Official Program Book includes the conference agenda, exhibitor and sponsor profiles, floor plan of the exhibit hall, and all special events. Your advertising message will reach all attendees at the show.

Europe/Russia/CIS/Africa/Middle East

Mike Elmes

P: +44 (0)1206 321639

Fax: +44 (0)1206 321259

E: mike.elmes@aerospacemedia.co.uk

All Americas/Canada

Beth Eddy/Mimi Smith P:

+1.561.279.4646

Fax: +1.561.279.4699

E: betheddy@aviationexhibits.com E:

mimismith@aviationexhibits.com

Singapore

Margaret Chong P:

+65 9736 1722

E: Margaret@accessgroup.aero

Asia-Pacific

Clive Richardson

P: +44 (0) 7501 185257

E: clive@accessgroup.aero

Aviation Week/Informa Markets is committed to running sustainable, socially responsible events that have a limited impact on the environment. Like all industries we are looking for ways to reduce our carbon footprint and the amount of waste our events produce.

Disposable, single-use stands, have a detrimental impact on the environment, both during construction and removal. The Better Stands initiative offers exhibitors ways to move away from disposable stands replacing them with high-quality reusable structures made with sustainable materials.

To reduce environmental impact, mitigate health and safety risks and maximize build and breakdown times, please review the guidelines below.

What is encouraged?

- All core elements i.e. walls, archways, counters etc. should be constructed with reusable materials e.g. system build or stock panels.
- Stand structure should be prefabricated and ready to assemble onsite.
- Final adjustments to prefabricated pieces for fitting purposes is fine.
- Final coat of acceptable TVOC paints should be for repair purposes only.
- The use of LED lighting.
- The use of recycled carpet, Eco vinyl flooring, other floor coverings.
- Floor flats and system floors should be cut to size before coming onsite and be recyclable and/or reusable.

What is discouraged?

- The use of one-time MDF panels or similar raw materials planned to be cut to size onsite.
- The use of 'other' raw materials to construct core structural elements i.e. walls, archways, floor systems, counters etc. that are not planned to be reused or recycled after use
- Construction of any stand components from single use materials.
- Building from scratch onsite of any stand core elements
- The use of incandescent light bulbs.
- The use of non-recycled carpet, PVC vinyl flooring, other floor coverings.

TERMINOLOGY

- **Reusable** A stock item which will be collected at the end of the event to be reused again at another exhibition.
- **Recyclable** The item is produced from materials which will be recycled after the event.
- **Recycled** Items used are made from recycled material.
- **Frame & Fabric** Stands designed from Frame & Fabric. Frames will be reusable. Fabric allows multiple use by saving it for the next show(s) and/or is recycled after the show. These types of stands are lighter and therefore generating less carbon emissions as they are transported to the event.
- **LED Lights** Energy efficient lighting option, reducing electricity usage of each bulb by 80% compared to conventional light bulbs.
- **Platforms and Carpet** Floor flats and system floors are cut to size before coming onsite and are recyclable and/or reusable. Carpet will be recycled.
- **Disposable Stand Structures** Space only stands made to be used only once which are usually constructed from raw materials at the venue during build up. The stands are demolished and disposed of after the event and the stand materials are not reused or recycled.

EVENT DATES:

17-19 Oct 2023

EXHIBITION

18-19 Oct

CONFERENCE

17-18 Oct

REGISTRATION

17-19 Oct

LOCATION:

Amsterdam RAI
 Halls 1/5

Advanced Freight – Refers to freight that has been sent to the Official Contractor’s warehouse prior to the Events move in.

Advance Order – An order for services sent to service contractor prior to installation date.

Aisle Carpet – The carpet that is placed on the Event floor in the aisles to separate the booths. The exhibit hall is not carpeted; however, all booths must have carpet or management approved flooring. Rental Carpet is available through Freeman. The aisles will be carpeted in RED.

Back Wall – Refers to the drape used at the rear of a standard booth.

Bill of Lading – A legal document that establishes the terms between the shipper (exhibitor) and transportation company (carrier) for the transport of goods between specified points for a specified charge. A bill of lading is required to be filled out and turned in at the Freeman Service Desk at the close of the show, after the exhibitor is all packed up, in order for Freeman to release the freight to the transportation company (carrier)

Booth Package – This term describes the equipment supplied to exhibitors from show management.

Certified Weight Ticket – Certified weight ticket is a required documented measurement used for shipping exhibit properties. All carriers checking into a venue’s marshaling yard are required to present a certified weight ticket at check in.

Common Carrier – A transportation company moving exhibitor freight, which usually only accepts crated materials that it can consolidate with the properties of other customers into one shipment bound for the same destination. Only Freeman can accept freight from a common carrier.

Corner Booth – An exhibit space with exposure on at least two aisles, usually found at the end of a row of inline booths.

CWT – “Century Weight” or “hundredweight”. The total weight of a crate is divided by 100 to obtain billable weight. 51,000 lbs / 100 = 510 cwt

Drayage – The service that includes delivery of materials to an exhibit space, removal of empty crates, storage of crates during the Event, return of crates at the end of the Event, and delivery of materials to the carrier loading area. See documents regarding Material Handling.

DT Labor – Double-time labor, or work performed on double time and charged at twice the published rate.

Empty Sticker – A colored sticker used to mark empty crates and boxes for storage provided in the material handling service. See Service Desk for Empty Stickers.

Exclusive Contractor – One who holds an exclusive contract with a facility or event manager to provide specified services to that facility or Event.

Exhibitor Appointed Contractor (EAC) – Also called an independent contractor, a supplier hired by an exhibitor to perform trade Event services independently of Event management-appointed contractors.

Exhibitor Kit – Also known as a Service Manual/Exhibitor Resource Center, this is package of information that contains all rules, regulations and ordering forms relating to an exhibition, provided to exhibitors by Event management.

Floor Order – An order for product or service placed after Advance Deadline therefore not eligible for discounted rates.

Floor Port – A utility box recessed in the floor containing electrical, telephone or plumbing connections.

EVENT DATES:

17-19 Oct 2023

EXHIBITION

18-19 Oct

CONFERENCE

17-18 Oct

REGISTRATION

17-19 Oct

LOCATION:

Amsterdam RAI
 Halls 1/5

Freight Desk – The area where inbound and outbound exhibit materials are handled at a trade event.

Forklift /Ground Rigging – Handling and assembly of machinery that requires the use of a forklift. This includes positioning and/or re-skidding of exhibitor material, machinery and equipment.

Hard wall – A type of exhibit construction in which walls are made of a solid material, rather than fabric.

I&D – Installation and dismantling of an exhibit by a labor source. Exhibitors may order this service from the general contractor.

ID Signs – Typically a 7” x 44” cardstock sign that contains exhibitor name and booth number.

In-line – An exhibit that is constructed in a continuous line with other exhibits.

Island Exhibit – An exhibit with aisles on four sides. There is no pipe and drape construction provided to Island booths.

Labor – Contracted workers who perform services. When labor is ordered, hours are based on estimates and will be billed actual time incurred. Requested times are not guaranteed and are based on availability. Minimum of one hour will be charged. Additional time will be billed in increments. Rates are based on when labor was performed: ST, OT, DT.

Logistics – Point to point transportation services for freight by an appointed carrier.

Marshaling Yard – A lot where trucks gather for orderly dispatch to Event site. When a marshaling yard is provided, all carriers must check in, present a weight ticket, and will be guided to the docks to unload when a space is available. The same is true for the out of the show. Applicable fee applies.

Move In – Refers to the date and time that exhibitors gain access to a facility and are able to begin the construction and/or set up of their booth.

Move out – The date/time specified by Event management for dismantling exhibits and clearing the exhibition floor. Also referred to as

Perimeter Booth – A booth space on an outside wall.

Pipe and Drape – Tubing covered with draped fabric to make up rails and back wall of a trade show.

Porter Service – A service that includes the emptying of wastebaskets within the booth at specific intervals during the show.

Quad Box – Four electrical outlets in one box provided by the electrical contractor.

Registration – This refers to an area that Event management uses to register and check in Event exhibitors, buyers and attendees. This is the place in which show badges can be obtained.

Rigger – A skilled worker responsible for handling and assembly of machinery.

Right-to-Work state – A state where no person can be denied the right to work because of membership or non-membership in a labor union. See the Union Rules and Regulations within your manual for specific guidelines.

Service Desk – The location at which exhibitors order services.

Side Rails – The wall between two booths used to divide exhibits, typically 3’ high.

Skirting – Decorative covering around tables and risers. Tables are skirted on 3 sides unless additional skirting is ordered.

Special Handling – An additional charge that applies to exhibits shipments requiring extra labor, equipment, or time for delivery to exhibit space.

ST labor – Straight time labor, or work performed during normal hours at the standard rate.

Visqueen – A clear heavy plastic sheeting that is placed over exhibiting carpeting after it is laid in order to protect it until show opens.

Stand/Booth Furnishings

What is Raw Space?

A Raw space booth is generally defined as a booth space wherein the exhibitor brings their own custom booth. The exhibitor purchases the space only from the organizer and all furnishings and services are ordered/brought/purchased a la carte.

What is Shell Scheme?

A shell scheme is a modular system of hard walling that is supplied built to the size of the booth purchased by the customer. At Aviation Week events, shell scheme stands include infill panels, 1 socket, 2 spotlights, a nameboard/fascia and carpet.

Who do I order extra furniture from?

Rental furniture is available for most Aviation Week events. You can find the official furniture vendor ordering information in the exhibitor resource center on the event's web site.

Can I put a logo on the top of my stand?

Shell Scheme exhibitors can purchase their own personalised fascia signs through the Freeman webshop.

How many walls does my stand come with?

Shell scheme stands typically have 2-3 walls. Inline stands will have 3 walls with the open side facing the aisle. Corner stands typically have 2 walls. If you are not sure how many walls your stand has, please contact the show organizer.

How many lights are supplied?

Each shell scheme stand will include 1x 500w Socket & 2 x 100w Spotlights.

How do I attach my graphics onto the wall?

Shell scheme wall panels are compatible with Velcro.

What are the walls made out of?

Shell scheme walls are constructed from Nyloop Infill panels.

What is loop nylon?

Loop nylon is a material that is compatible with velcro.

Can I change the panels from loop nylon to foamex?

No.

What colour are the wall panels?

For MRO Europe, the panels are white.

How do I attach a TV onto the wall?

Screen brackets should be available through the Freeman webshop

Do you supply underlay/padding?

No. Carpet is included with the shell scheme stands, however if you would like to add padding to your stand then this can be purchased through the Freeman webshop. Raw space stands can order additional padding from the floor coverings catalog via Freeman or bring your own.

What colour carpet do I receive? Can I change the colour of this? Carpet is included for shell scheme stands only. Shell scheme stand carpet will be grey. Carpet can be ordered at the exhibitors expense. All stands (raw and shell) must be carpeted. You can order from Freeman's floorcovering catalog in in the exhibitor resource center or bring your own. If you are not ordering from Freeman, please let them know so that you will not be charged for floor covering.

What type of graphics do you supply?

The only graphic supplied is White vinyl lettering to a 300mm high Royal Blue fascia infills to each open elevation on shell scheme stands. Raw space stands do not include any graphics.

Can I upgrade my package 500w socket to a 1kw socket?

Please contact the RAI Exhibitor Services Team.

Can Freeman construct my booth from start to finish?

Freeman offer stand design and build support, to enquire please email EMEA.ExhibitorServices@freemanco.com

What does my island/raw space booth come with?

Your island/raw space booth does not include any furnishings. It is space only.

Can I remove the shell from the booth

If you have purchased your booth as shell scheme, the shell scheme cannot be removed. It is imperative that the gridwork stay in place so as not to compromise the structural integrity of the surrounding booths. Please refer to the display rules for further details.

Display Rules/Guidelines

How do I submit my stand plans for approval?

All Island and/or raw-space booths must submit their plans online: [MRO Europe 2023 - Stand Submission Form \(smartsheet.com\)](#)

The deadline for stand design submissions is September 1, 2023.

How do I know if I need to submit stand plans for approval?

All island and/or raw-space booths must submit plans for approval by the stated deadline.

What information do you need from us to hire a different contractor for our carpeting needs?

Please contact Freeman and alert them that you will be bringing your own carpet.

Tel: +44 (0) 2477 9900198 | EMEA.ExhibitorServices@freemanco.com

All contractors need to complete the EAC form:
<https://fs2.formsite.com/AW-Events/form58/index.html>

How high can I build my booth?

For complete rules and guidelines, please visit the display guidelines section of the ERC on the event web site.

All shell scheme booths at MRO Europe are 2.48 meters high. Island booths may build up to 4m. Island booth exhibitors can request permission from show management to build up to 6m, which is deemed a complex stand.

What do the additional fees for a double decker cover?

Double-decker (multi-story) booths require additional structural approvals, fire watch, fire marshal approvals, etc. The additional fees cover these approvals as well as air rights to the space.

Can I move in early?

Early access/late working is not permitted. Please check the exhibitor resource center for move-in/move-out timings. Please adhere to the move-in schedule that is designated for your type of booth.

Can I tear down early?

No. No exhibitor is to begin teardown or packing process until the Exhibit Hall closes. If you are unable to keep to the exhibit schedule you should reconsider exhibiting. Early teardown of one's exhibit will result in booth selection penalties the following year.

There is a two-part reason behind this policy. First, we still have clients entering the show and they have been promised that the full package of exhibitors will be present. By leaving early, you may be the one exhibitor they really wanted to visit and are now robbed of that opportunity. Second, it impacts your fellow exhibitors. Early teardown not only creates a visual eyesore and a possible physical obstacle to accessing other exhibitors, but it also sends a psychological message to clients that time is up and they need to stop visiting other exhibitors

Freight/Shipping

Can I send materials to the venue?

Venues will not accept deliveries directly. On-site deliveries are strictly prohibited until official show dates. All on-site deliveries need to be coordinated through our on-site logistics partner.

What do I do with my empty containers

Storage for empty containers can also be coordinated through our on-site logistics partner.

EACs and Insurance

Does my regular General Liability insurance work for this show, or would I have to add it on my policy?

Most general liability insurance companies offer this coverage. However, you would need to speak directly with your carrier to determine if it is included in your policy.

Does both the exhibitor and the contractor need to supply a COI? Does the stand designer need to supply a COI?

Yes. Everyone working on the show floor needs to provide a COI.

Can you recommend an insurance company?

Aviation Week doesn't recommend any specific insurance company. You should contact the holder of your general liability insurance policy and see if they supply this kind of coverage.

Where do I get a COI? What does it need to cover?

You should contact the holder of your general liability insurance policy and see if they supply this kind of coverage.

Exhibitor is required to carry property and liability insurance in amounts sufficient to cover any losses or liabilities exhibitor may incur in connection with the Show, including without limitation, due to damage or loss to exhibitor's property or injury to the person and/or property of others. Notwithstanding the foregoing and except as otherwise provided in the Exhibitor Resource Center, at all times that exhibitor has access to the Show grounds, exhibitor shall maintain at a minimum the following insurance from an insurance company rated B+ or above by A.M. Best Company (or equivalent insurance rating agency):

- General commercial liability insurance, including contractual liability and advertising injury coverage, with a minimum liability limit of not less than \$1,000,000 combined single limit per occurrence and \$2,000,000 aggregate.
- Exhibitor's policy should add Informa Media, Inc. and Informa Business Media, Inc. and their respective affiliates, the applicable Show facility, and/or any other official exhibitor service contractor as additional insureds.
- By executing the Agreement, exhibitor represents and warrants that it has all such insurance in effect and that it shall maintain all such insurance at least through exhibitor's occupancy of the exhibit space and the Show facility.

If requested by Show Management, exhibitor shall provide a certificate of insurance evidencing the required coverage.

Exhibitor Services

Can I bring a Keurig, espresso machine, champagne tower, sausages, Turkish Delight, bottled water, cotton candy machine, whisky, etc.?

All food and beverage needs to be supplied by the official catering vendor for all MRO Events. If an exhibitor wants to serve an item that is not offered by the official catering partner, permission can be requested from show management.

Is it possible to have two entries in the program book?

Additional program book entries can be purchased from your sales representative.

What is the cost to exhibit at this show?

Please contact your sales representative for pricing and availability. Sales reps are determined by geographical location. To find your representative, please visit: <http://events.aviationweek.com>

What is MRO Links? How is this different from my program book pro- file?

MRO Links is a visibility and lead generation program that continues your MRO presence all year long. Your links profile is added to a database that generates leads throughout the year. Your program book profile is printed in the show program book, posted on the event web site and on the event app (when applicable).

Has our exhibit space been paid for?

To confirm that your exhibit space has been paid in full, please contact your sales representative.

Registration

How many exhibitor badges do we get?

Booth personnel is unlimited at all MRO shows.

How should we register to be exhibitors for the show?

Exhibitors should visit the registration page on the event web site. There are a variety of options for exhibitors to register booth personnel and conference sessions. Exhibitors are entitled to conference discounts. Please contact events@aviationweek.co.uk for more information.

Can I have list of attendees?

Due to Informa's corporate privacy policy, attendee contact information cannot be shared.